

**हर एक काम
देश के नाम**



GAIL INDIA LIMITED

**CONSTRUCTION & LAYING OF FIRE WATER NETWORK INSIDE THE
GAIL TERMINAL AT SUVELI**

VOLUME II OF II (TECHNICAL)

(BID DOCUMENT NO - 034/LEPL/GAIL/27 - R0)



E-TENDER REF : 8000017579

OPEN DOMESTIC COMPETITIVE BIDDING



Lyons Engineering Pvt. Ltd.



PMC: 	DCI - CONSTRUCTION & LAYING OF FIRE WATER NETWORK INSIDE THE GAIL TERMINAL AT SUVELI	Doc No.		CLIENT: 
		GAIL-ENG-GN-DOC-DL-001		
		Rev. 0		
Sr. No.	Description	Document / Drawing No.		Rev. No.
	TECHNICAL VOLUME - II OF II			
A	SCOPE OF WORK	GAIL-RFP-GN-DOC-SW-001		0
B	DESIGN BASIS	GAIL-RFP-GN-DOC-DB-001		0
C	FIRE WATER PIPING GAD FOR CAIRN SUVELI	00005-PL-FW-DR-001		
D	STRUCTURAL DETAILS FOR PIPE SUPPORTS FOR FIRE HYDRANT SYSTEM AT SUVALI.	GAIL-STD-CV-DWG-PS-001		0
E	TECHNICAL SPECIFICATIONS FOR FIRE HYDRANT SYSTEM.	GAIL-STD-FF-DOC-TS-001		0
F	DATA SHEET:			
	Data Sheet for Gate Valve	GAIL-STD-PI-DOC-DS-001		0
	Data Sheet for Double headed Fire Hydrant system	GAIL-STD-PI-DOC-DS-002		0
	Data Sheet for Water Monitor	GAIL-STD-PI-DOC-DS-003		0
	Data Sheet for Fire Hose Cabinet & Accessories	GAIL-STD-PI-DOC-DS-004		0
G	FORMS & FORMATS :			
H	LIST OF APPROVED VENDORS			
i)	List of Approved Parties for Bought Out Items	GAIL-ENG-GN-DOC-VL-001		0



GAIL INDIA LIMITED

**CONSTRUCTION & LAYING OF FIRE WATER NETWORK INSIDE THE
GAIL TERMINAL AT SUVELI**

SCOPE OF WORK

GAIL-RFP-GN-DOC-SW-001

0	18.09.2020	Issued For Bid	SR	TR	SB	
Rev	Date	Purpose	Prepared By	Checked By	Approved By	

ABBREVIATION

API : American Petroleum Institute

FM : Factory Mutual

GWP : Global Warming Potential

ILBP : Inline Balanced Pressure Proportioner

IS : Indian Standard

LPCB : Loss Prevention Certification Board

LPM : Litres Per Minute

NFPA : National Fire Protection Association

ODP : Ozone Depletion Potential

OISD : Oil Industry Safety Directorate

UL : Underwriters Laboratory

Scope of Work for Construction & Laying of Fire water Network inside the GAIL Terminal at Suveli.	Doc No.	Rev	 Page 4 of 86
	GAIL-RFP-GN-DOC-SW-001	0	
	Page 2 of 15		

TABLE OF CONTENTS

TABLE OF CONTENTS 3

1. INTRODUCTION..... 5

2. WORK TENDERED 6

3. SCOPE OF WORK 6

4. DETAILED SCOPE OF WORK 8

5. CONTRACTOR'S RESPONSIBILITIES 13

1. INTRODUCTION

GAIL (India) Limited, the largest state-owned natural gas processing and distribution company and the youngest Maharatna company. GAIL is the nodal agency for transportation and supply of Natural Gas to various potential customers. The receipt of gas from the sources and its transportation and distribution is intended to be by means of a high-pressure trunk transmission gas grid from the gas receiving point to various customer stations.

M/s Cairn India Ltd. (CIL), Oil and Natural Gas Corporation Limited (ONGC) and Tata Petrodyne Ltd. are the Joint Venture Partners operating the “Lakshmi and Gauri Fields” Comprising of the three offshore wellhead platforms in the CB-OS / 2 block located in Gulf of Cambay and Onshore Oil & Gas Processing Facilities at Suveli.

GAIL intend to install Firefighting water system inside the GAIL terminal at Suveli as per OISD & PNGRB requirements. Work shall include all the piping, Valves, Fittings and Flanges, Double head fire hydrant and Active monitor etc.

Lyons Engineering Private Limited (LEPL) has been appointed as Engineering & Project Management Consultant by GAIL for the project.

Definitions:

Project	Construction and Laying of Fire water network inside the GAIL Terminal.
Owner/Company	GAIL (India) Limited
Consultant	Lyons Engineering Pvt. Ltd. (LEPL)
Construction Contractor	Survey, Residual Engineering, Procurement and Construction etc, providing the required services.
Manufacturer, Vendor (or Supplier)	The organization selected to manufacture or supply the equipment, services or material, ordered in accordance with Technical Specification, data sheets etc.

Fire hydrant shall be provided inside the GAIL Terminal at Suveli which is inside M/s CAIRN-Vedanta Plant at Suveli, Hazira as per the OISD, PNGRB & NFPA requirement for the protection of equipment and personnel from heat radiation.

The fire hydrant system shall provided instantaneous supply of pressurized fire water through fire water network to fire water cum foam monitors, fire hydrants and foam system for the purpose of manually suppressing fire.

This document covers minimum requirement for the various activities to be performed by the contractor for the engineering and construction of Mechanical Works for fire protection System (Fire water spray, pipe laying etc.), Civil works, Fabrication, structural steel, Piping, Fittings, Fire Hydrant equipments etc. and associated works. This document shall be read in conjunction with List of Attachments, Schedule of Rates, specifications, standards, drawings and other documents forming a part of the Tender Document.

Scope of Work for Construction & Laying of Fire water Network inside the GAIL Terminal at Suveli.	Doc No.	Rev	 Page 6 of 86
	GAIL-RFP-GN-DOC-SW-001	0	
	Page 4 of 15		

1.1 PROPOSED FACILITIES:

Laying of new aboveground fire water network piping with isolation valves, fittings, bends in the plant at few areas as per the drawing.

Installation of available and new hydrants and monitors as per OISD stipulations.

1. Fire water ring mains shall be sized for 120% of the design fire water flow rate and 10 Kg/cm²g.

2. Fire hydrant shall be designed for a minimum pressure of 7 Kg/cm² g at the most hydraulically remotest point in the installation. A pressure gauge shall be installed at the hydraulically remotest point so as to easily monitor the pressure at that point.

Hydraulically remotest hydrant or monitor is the one located at the farthest distance from the pump or located at the end of a poorly sized branch line, and encounters maximum pressure drop, at the designated flow rate at that point.

3. Fire-water mains shall be equipped with double headed hydrants to which hoses can be Connected. The number and position of hydrants shall be sufficient to permit effective firefighting.

4. Hoses, nozzles, valve keys, etc. should be stored adjacent to hydrants. Each hydrant shall be provided with a hose box equipped with two numbers of standard fire hose and multipurpose foam cum water spray nozzle.

5. Each monitor shall be capable of discharging under jet and spray conditions.

6. Monitors shall be water cum foam type.

7. The design of monitors shall consider location, size of supply piping, arrangement of control valves.

8. Suitable orifice plates shall be provided for the hydrants and monitors to limit the pressure to 7 Kg/cm² g at hydrant & monitor inlet and also for spray and foam systems to limit the pressure as per requirement.

9. Number of isolation valves on main header must be decided in such a way that at a time not more than one segment (portion of line between two junctions) of fire water line is isolated.

10. Isolation valve shall be gate valve having open/close indication which can be opened easily and quickly by one person.

11. All isolation valves shall be kept Locked Open.

12. Valves larger than six inches in diameter should be equipped with a gear mechanism to facilitate opening.

13. The isolation valves shall be easily identifiable and located where they are accessible during fire and should be close to the loop junctions.

Scope of Work for Construction & Laying of Fire water Network inside the GAIL Terminal at Suveli.	Doc No.	Rev	 Page 7 of 86
	GAIL-RFP-GN-DOC-SW-001	0	
	Page 5 of 15		

14. The fire water network piping should normally be laid above ground at a height of at least 30 cm above finished ground level.

15. The ring main shall be laid underground at the following places (as applicable):

- a. Road crossings.
- b. Places where above ground piping is likely cause obstruction to operations and vehicle movement.
- c. Places where above ground piping is likely to get damaged mechanically.
- d. Within 0.15 bar over pressure contour in plant areas where explosions cannot be excluded.

16. The fire water mains shall be supported at regular intervals not exceeding 6 m. For pipeline size less than 150 mm, support interval shall not exceed 3 m.

17. Pipe supports and hangers should be designed for potential damage from impact and over pressure.

18. The piping system shall be hydrostatically tested for 4 hours at 1.5 times the design pressure.

19. Fire water mains, hydrant and monitor stand posts, risers of water spray system shall be painted with "Fire Red" paint as per IS: 5. Anti-Corrosion coating/paint shall be used in corrosion prone areas.

2. WORK TENDERED

Work tendered in this bid package consists residual engineering, procurement, supply, installation, testing, pre-commissioning and commissioning of firefighting system.

The work involves is as follows:

- 1. Supply and Laying of aboveground fire water line including valves, flanges & fittings, Double headed fire hydrants, monitors etc. wherever required.
- 2. Civil & structural works including supply of all materials for pedestals, pavements, repair etc.
- 3. Complete erection & assistance in commissioning of firefighting arrangements.
- 4. Any other work not mentioned but required for successful completion of work.
- 5. Work may be allotted to Contractor in multiple Front. Contractor shall be required to plan and mobilize his resources accordingly to meet completion target Schedule of Owner.

3. SCOPE OF WORK

The work shall be completed conforming to Engineering Design Basis, technical Specifications, drawings, data sheets as furnished in the tender and any other information Provided by Engineer-In-Charge. The general scope of work includes the following.

Scope of Work for Construction & Laying of Fire water Network inside the GAIL Terminal at Suveli.	Doc No.	Rev	 Page 8 of 86
	GAIL-RFP-GN-DOC-SW-001	0	
	Page 6 of 15		

I. SURVEY & SITE VISIT (TERMINALS)

Contractor shall make site visits for terminal stations as per bid requirement. Indicative plot plan drawing for terminal station is provided for reference purpose. Contractor shall Revalidate the same before execution of the works.

II. PROCUREMENT OF MATERIALS & SUPPLY AT SITE

The facilities provided consist of the following units:

- i) Closed Fire Water Piping Network.
- ii) Double Headed Fire Hydrants, Active Monitors, Hose Boxes containing fire hoses with standard accessories, hose reels etc.
- iii) Fixed Medium Velocity Water Spray System with nozzles, Gate valve, Flange & Fittings etc.

Contractor shall procure and supply all materials other than Company supplied materials, required for permanent installation of piping system in sequence and at appropriate time as per approved schedule requirements. All equipment, materials, components etc. shall be suitable for the intended service.

Approved vendor list has been enclosed with the bid package for various items. For items which are not covered in the vendor list, Contractor shall obtain Company’s prior approval for the vendor. Equipment/ material offered shall be field proven. Equipment requiring Specialized maintenance or operation shall be avoided, as far as possible.

Stores management including receipt, warehousing, preserving the material in good condition, issue of material to construction site, reconciling/ handing over surplus material to Company for Company supplied items at Company’s storage yard.

Carryout proper documentation of inspection and quality assurance programmers for bulk materials duly approved by Company. Contractor shall maintain an accurate and traceable listing of procurement records for the location, quality and character of all permanent Materials in the Project.

Contractor shall immediately report to the Company of all changes which will affect material quality, and recommend any necessary corrective actions to be taken.

Submit periodic manufacturing progress reports highlighting hold ups and slippages, if any, to Company and take remedial measures.

Interact with authorities such as Sales tax, Octroi, Excise, GST etc. as necessary and arrange for dispatch of materials to site.

All purchase requisitions including purchase orders shall be approved by Company.

Compliance with vendors and supplier’s instructions and recommendations for transportation, handling, installation and commissioning.

Contractor shall provide inspection of the items at vendor’s works by the reputed inspection agency and shall submit inspection reports of OWNER’s clearance. In addition to the same, OWNER reserves the right to inspect any material supplied by the contractor at any stage of

Scope of Work for Construction & Laying of Fire water Network inside the GAIL Terminal at Suveli.	Doc No.	Rev	
	GAIL-RFP-GN-DOC-SW-001	0	
	Page 7 of 15		Page 9 of 86

manufacturing and delivery by themselves or through their representative. Contractor scope includes to provide the intimation to the owner, for inspection at any stage. This intimation shall be given at least 10 days prior to the inspection. Any extra payment will not be release to the contractor due to this inspection. Contractor shall appoint anyone of the following TPIA for inspection purpose.

- i. Lloyds Register of Industrial Services.
- ii. Technischer Überwachungs Verein (TUV)
- iii. Det Norske Veritas (DNV)
- iv. AIB – Vincotte
- v. Bureau Veritas
- vi. SGS
- vii. American Bureau Services (ABS)
- viii. Velosi Certification Services.

A. Materials to be supplied by Company as Free Issue

i. Client shall supply following materials as free issue:

- DN - 8 INCH, IS: 3589, 6.35Thk.-Heavy– 150 Mtrs.
- 4” Gate Valve-GR WCB, ASTM A216, FLGD, 150# - 4 Nos.
- 8” WNRF Flanges, Rating PN 1.6, Material as per Pipe. – 4 Nos.
- 4” WNRF Flanges, Rating PN 1.6, Material as per Pipe. – 8 Nos.
- 8” Blind Flanges, Rating PN 1.6, FF – 1 Nos.
- 4” Blind Flanges, Rating PN 1.6, FF. – 1 Nos.

ii. Free issue material shall be supplied from M/s GAIL designated stores as instructed by Engineer In charge. Further, Contractor shall also return any unused materials after completion of work to owners designated store or as directed by owner/ Engineer-in –Charge at its own cost.

B. Materials to be supplied by Contractor

All materials (other than those mentioned in clause A above, consumables, equipment required for completion and successful commissioning of entire pipeline system shall be procured and supplied by the Contractor As a minimum, the materials to be supplied by Contractor shall, but not limited by any way, be as follows:

- i. The procurement and supply, in sequence and at appropriate time, of all materials and consumables required for completion of the Work as defined in this bid document except the Company free issue material, shall be entirely the Contractor’s responsibility and price quoted for the execution of the Work shall be inclusive of supply of all these materials.
- ii. All materials supplied by the Contractor shall be strictly in accordance with the requirements of relevant Company material specifications enclosed with the tender document.
- iii. All equipment’s, materials, components etc. shall be new and specifically purchased for this job. All material to be supplied by the Contractor shall be purchased from the approved vendors of the Company, duly inspected by LEPL/ Third party inspection agencies like Lloyds, Bureau Veritas etc. The list of approved vendor is enclosed along with bid document.

Scope of Work for Construction & Laying of Fire water Network inside the GAIL Terminal at Suveli.	Doc No.	Rev	 Page 10 of 86
	GAIL-RFP-GN-DOC-SW-001	0	
	Page 8 of 15		

- iv. All stud bolts, nuts, all type of gaskets (metallic spiral wound / ring type) in required quantities to be used for permanent installation into the system for all sizes and ratings of flanges and flanged valves, equipment etc.
- v. All consumable such as welding electrodes, oxygen, acetylene, inert gases, all types of welding electrodes, filler wires, solder wires, brazing rods, flux etc. for welding/cutting and soldering purposes.
- vi. All primer and paints for painting above ground piping shall be as per specification enclosed with the bid package.
- vii. All safety tools and tackles, devices, apparatus, equipment, personal safety gazettes to be used as personal protective equipment (such as helmets, safety belts, safety shoes, etc.) including ladders and scaffolding etc. complete as recommended by Engineer-in-Charge as per relevant safety standards.
- viii. All structural steel material for all types of supports.
- ix. All materials and equipment for excavating trench or grading the Right-Of-Use pipeline and pipe laying / installation and other works.
- x. All steel materials such as structural steels, reinforcement steels and steel for all types of supports, foundations, ladders, platforms etc. including Bolts, nuts, washers, U bolts, clamps, clips, gaskets, Shims, wedges and packing plates (Machined wherever required) and materials required for fabrication of low friction sliding bearing supports.
- xi. All materials, manpower, spares, tools & tackles and consumables for carrying out pre-commissioning activities and during commissioning.
- xii. All Civil/Structures items, Piping, Flange and fittings materials in complete as per requirement specified in all different sections.
- xiii. Any other material not specifically listed herein, but required for successful completion of the Work.

C. Storage of Materials:

- i. All materials shall be preserved against deterioration and corrosion due to poor or improper storage while under the custody of the Contractor.
- ii. All materials shall be duly protected by the Contractor at his own cost with the appropriate preservatives like primer, lacquer, coating, grease etc. and shall be covered with suitable material to prevent them from direct exposure to sun, rain, wind and dust.
- iii. Pipes shall be stacked according to the identification marks and stacks shall be arranged on sleepers / sand bags at least 300 mm above ground.
- iv. The Contractor shall check that valves, fittings, specials etc. are not subjected to corrosion from hydrostatic test water remaining in the piping. Any such condition when detected should be brought to the notice of Engineer-in-Charge and remedial measures taken as directed.
- v. All machined surface shall be properly greased and should be maintained and protected from damages.

vi. Openings of equipment, machinery, valves etc. shall be kept blocked / covered with blinds to prevent entry of foreign matter.

vii. As far as possible materials shall be transported to the site of erection only just prior to the actual erection and shall not be left around indefinitely on ground but kept on packing/sleepers etc. to maintain the minimum distance from the ground as specified and/or as per directions of Engineer-in-Charge.

III. QUALITY ASSURANCE & QUALITY CONTROL

- a. Contractor shall prepare Quality Assurance & Quality Control Plan for project.
- b. Contractor shall ensure adequate quality assurance and control including stage wise inspection, testing and certification.
- c. Contractor shall appoint an independent TPIA for supply of material (Other than free issue) from Owner’s vendor list. The TPIA appointed by contractor shall be common for inspection of complete scope of supply. All inspection reports shall be submitted for owner’s review/approval. All materials like station pipes, fittings, valves etc. shall be supplied with required certificate / approved document.
- d. Contractor shall Carryout proper documentation of inspection and quality assurance programme for all equipment and bulk materials duly approved by Owner.
- e. QAP samples are enclosed as part of bid shall be followed by Contractor without any deviation as is basis.

IV. CONSTRUCTION: INSTALLATION, ERECTION & TESTING

- a. Contractor shall carry out construction work as per approved “Issued for Construction” drawings, procedures, specification and applicable codes and standards. Any changes at site shall need prior approval from the Engineer-In-Charge.
- b. Contractor shall receive and takeover of all owner supplied free issue materials (if applicable) from the designated place(s) of issue. The transportation including loading, unloading, handling, storing till installation of materials shall be the responsibility of contractor.
- c. Contractor shall be responsible for delivery and handling of bought out material at site.
- d. Contractor shall prepare planning and monitoring schedule.
- e. Contractor shall mobilize adequate manpower, machinery, tools, tackles, consumables etc. for construction. Immediately after award of individual work, Contractor shall make a visit to the terminal and familiarize with the working conditions so as to plan for deployment of manpower and machinery.
- f. Contractor shall do clearing and grading of station plots. where mechanized excavation is not possible, Contractor shall have to do manual Excavation also.
- g. To ensure adequate quality control, contractor shall make arrangement for stage wise inspection and testing during construction work at site.
- h. Contractor shall carry out fabrication of station piping and construction & installation of pipe supports.

Scope of Work for Construction & Laying of Fire water Network inside the GAIL Terminal at Suveli.	Doc No.	Rev	 Page 12 of 86
	GAIL-RFP-GN-DOC-SW-001	0	
	Page 10 of 15		

- i. Contractor shall make proper waste disposal system for construction and related works.
- j. Contractor shall carry out all incidental and associated works and any other works not specifically listed there in but are required to be carried out to complete entire work related to pipelines and terminals.
- k. To obtain No Objection Certificate from OISD / TAC / local government fire authorities for the complete system.
- l. Contractor shall carry out Induction and strict implementation of Health, Safety & Environment (HSE) procedures including safety organization, HSE plan, providing PPE, providing adequate barricades at work site wherever required, conducting periodic audit and ensuring the implementation of HSE measures. Contractor shall be fully responsible & liable for ensuring & implementing HSE at site & shall hold Engineer-In-Charge fully indemnify from all liabilities & consequences.

V. PRE-COMMISSIONING & COMMISSIONING

Contractor shall carry out Pre-Commissioning of complete system. Overall commissioning activities for entire system in both the terminals shall be performed by the Contractor. Contractor shall mobilize all equipment, consumables, and manpower for carrying out commissioning activities as per direction of Engineer-In-Charge.

VI. PROJECT MANAGEMENT INCLUDING DOCUMENT CONTROL SYSTEM

Preparation of detailed project schedule.

Preparation of Project Execution Methodology.

Material Management Plan

Planning & Scheduling

Monitoring and Reporting of progress on each front of the project.

Contractor shall be required to work on the material management module of GAIL. Service entry sheet of goods received and invoice entry in SAP capturing to be done by the Contractor.

Deployment of competent qualified & experienced Project & Construction Personnel. Key manpower shall meet the requirements specified in bid document. Contractor shall submit site organogram with CV of respective personnel to Engineer-In-Charge.

Expediting and Monitoring of all procurement excluding free issue material and construction activities with approved vendors / sub-Contractors.

Contractor shall submit following deliverables for adequate monitoring of project:

- Daily Progress Report (DPR) for construction works of project
 - Weekly Progress Report (WPR) for Procurement covering all stages of material Including construction progress.
 - Monthly Progress Report (MPR) with comparison.
- The details of content of the above reports shall be prepared by the Contractor for approval of Engineer-In-Charge.

VII. PROJECT CLOSE OUT

Submission of all as built documentation, inspection reports, purchase orders, material reconciliation report etc. both in soft and hard copy duly approved by Engineer-In-Charge.

Scope of Work for Construction & Laying of Fire water Network inside the GAIL Terminal at Suveli.	Doc No.	Rev	
	GAIL-RFP-GN-DOC-SW-001	0	
	Page 11 of 15		Page 13 of 86

Submission of relevant documents, Operation & Maintenance manuals, guarantee/ warrantee test certificates of all the items supplied by Contractor for the execution of the complete scope of work.

Submission of operational acceptance report including all the documents, test certificates etc.

- Pre-Commissioning and Commissioning
- Pre-Commissioning of complete system
- Commissioning of fire water spray system and associated facilities including supply of materials (temporary, permanent or consumables), tools and tackles (including special tools & tackles) and manpower.

VIII. OWNER'S RESPONSIBILITY

- a) Issuing clearance to contractor to work in the GAIL premises only
- b) Free Issue Material (as applicable)
- c) Refer commercial volume

4. DETAILED SCOPE OF WORK

The main intentions of provision of firefighting systems are to extinguish the fire at its inception or to control its spread and to assist the fire department in taking required action and thereby reducing the loss suffered as a result of fire.

The fire protection system envisaged for the plant calls for early detection of fire and quenching the same by various systems envisaged besides giving out an audio-visual alarm.

The firefighting arrangements cover the provision of portable fire extinguishers, etc. as per the requirement of OISD: 116 & OISD:226 and TAC.

4.1 Hydrant Service

A well-designed Hydrant system is the backbone of entire firefighting system as it fights fire of all classes of risks.

The work shall be carried out as per OISD:116 & OISD:226. The pipes used shall be Carbon Steel as per IS: 3589 / IS:1239 or its equivalent. Isolation valves used shall be Cast steel as per API Class 150.

Distribution mains form ring around each new proposed area, which is connected to the ring main running in the vicinity. The network will be laid generally above ground. Wherever it is laid Underground, it should be laid at an average depth of 1m below ground level and 1.2M (Min.) below the ground level at road crossings. All such underground pipes shall be provided with suitable corrosion protection as per IS:10221. Each area is being covered with adequate numbers of fire hydrants and water monitors. Fire hydrant network drawing showing the tentative location of hydrants, monitors, valve pit is enclosed with the tender. The fire protection system will also have hose reels, hose boxes, isolation valves, flanges, fittings along with complete electrical and instrumentation work etc. All double headed hydrants, monitors and hose reels shall be provided with a cut-off gate valve on tapping (stand post) from main fire water header with ISI / TAC approval. Hydrants and monitor connections shall be through 4" line. Double outlet hydrant valves shall be laid above ground at an height of 1.2M. At least 10% of all welded joints shall be radiographically tested and half of radiographed joints shall be field joints.

Scope of Work for Construction & Laying of Fire water Network inside the GAIL Terminal at Suveli.	Doc No.	Rev	 Page 14 of 86
	GAIL-RFP-GN-DOC-SW-001	0	
	Page 12 of 15		

Hose boxes with all accessories shall be provided at locations in line with TAC guidelines and construction of hose box shall be made as per specifications given in OISD-115. Hose boxes shall be provided at every alternate hydrant in the network.

Each hose box shall consist of two hoses of 63mm dia. 15m long RRL each with end couplings, 2 nos. jet nozzles with branch pipe or two universal branch pipe as per IS: 903. Hoses shall confirm to IS: 636 type-B.

Hose reels shall be considered as first aid fire contingency at strategic locations / units like control room and administrative building, non-plant rooms etc. Hose reels shall be located 40m apart and shall cover all parts of the buildings in ground floor. Hose reels shall be floor-mounted type and they shall have water connection from hydrant network.

Above ground fire water pipes shall be painted fire red confirming to shade no. 536 of IS:5. All fire water piping shall be hydro tested to a pressure of 18 Kg/cm². Adequate nos. of isolation valves in the fire water network shall be provided to ensure easy maintenance at the affected part of the network and at the same time uninterrupted water supply to the rest of the network for firefighting remains available.

Complete fire proofing of equipments in unit shall be carried out as per OISD:164.

5. CONTRACTOR'S RESPONSIBILITIES

Contractor's responsibilities, besides the scope of work to be performed by him defined earlier, shall also include the following:

- a. Appraisal and taking cognizance of site-conditions, pipe route, applicable Indian Standards and Codes, specific requirements of the work and made due allowance for it in the work to be performed by him.
- b. The work to be done inside the M/s CAIRN-Vedanta Plant compiling to all the safety rules and regulation of M/s CAIRN-Vedanta, Suveli.
- c. The contractor to take the various work permits from CAIRN-Vedanta as per their rules.
- d. The contractor to take entry pass for their work force, materials, vehicles etc. to CAIRN-Vedanta as per their rules.
- e. The contractors to deploy sufficient certified work force like riggers, fitters, helpers, welders, hydra operators etc. for erection firefighting network.
- f. The contractor has to deploy certified/calibrated tools and tackles, equipment etc. for erection of firefighting network.
- g. Company shall provide the available information and gives no guarantee or warranty as to the accuracy or completeness of the information provided. It is the Contractor's sole responsibility to obtain sufficient information / data for finalization of Plot Plan and Foundation drawings to start the construction work.
- h. Interpretation and verification of data/information furnished by Company in respect of pipe route contained in the bid package. Any additional information/data/surveys etc. required by Contractor for residual engineering and execution of the works shall be obtained by him.

Scope of Work for Construction & Laying of Fire water Network inside the GAIL Terminal at Suveli.	Doc No.	Rev	
	GAIL-RFP-GN-DOC-SW-001	0	
	Page 13 of 15		Page 15 of 86

- i. Residual engineering including drawings and installation procedures, engineering for Procurement & fabrication, engineering for installation including drawings, QA/QC procedures, etc performed by the Contractor shall be reviewed and approved by Company.
- j. Contractor shall submit engineering documents, drawings, procedures in hard copy to Company before start of construction work at site. All works shall be executed based on Approved documents only.
- k. Contractor shall prepare general arrangement drawing, isometric drawing & bill of materials, vendor engineering drawing & documents etc. and submit the same from Owner/ Consultant's approval/ record. Contractor shall prepare drawing for utilities line as required as per SOR and submit the same for Owner/ Consultant's approval /record.
- l. Review and approval of Contractor's entire work(s) or approved IFC drawing provided by Company shall in no way relieve the Contractor of his sole responsibility for safe and efficient design, engineering, installation and subsequent operation of pipeline system.
- m. Furnishing and mobilizing at site(s) of all construction equipment, manpower, tools and tackles, construction spreads, fully equipped and fully manned with other required support facilities etc. commensurate for spreads needed for successful execution of the works.
- n. Contractor shall depute independent third-party inspector for carrying out radiographic inspection/ UT and interpretation of radiograph/ UT of welds. Third party inspector shall be approved by Company.
- o. Pre-commissioning/ commissioning of entire piping system.
- p. Preparing and furnishing calculation books, pipe books, material/ purchase requisitions, final purchase orders including specifications, Vendor's data books (including Guarantees), fabrication and construction drawings, all survey reports, inspection and testing reports, as-built records for all phases of work.
- q. The Contractor is cautioned to exercise extreme care and take necessary precautions to prevent damage to the existing pipeline(s), facilities, electrical and other cables during execution of the entire works. Restoration/reconstruction of all structures/ facilities affected during pipeline construction shall be carried out by Contractor.
- r. Any claims arising out of noncompliance to the above requirements, as granted by competent authorities shall be to Contractor's account.
- s. Contractor shall carry out all testing and inspection of materials, equipment etc. in independent testing institutions, laboratories, if so desired by Company.
- t. Disposal and treatment of treated hydro-testing water, excavated materials, surplus materials etc. as per local authority's requirements.
- u. All works shall be carried out by Contractor strictly in accordance with the Drawings/documents/specifications indicated in the list of attachment document.
- v. Any other work not specifically listed but required for successful completion of entire fire water network system.

Scope of Work for Construction & Laying of Fire water Network inside the GAIL Terminal at Suveli.	Doc No.	Rev	 Page 16 of 86
	GAIL-RFP-GN-DOC-SW-001	0	
	Page 14 of 15		

MANDATORY REQUIREMENT:

- i) Mandatory requirement of safety engineer at site
- ii) All COVID-19 safety factors (all testing of COVID as per GAIL testing) and other safety requirements are to be taken care, contractor need to take approval from M/s CAIRN. CAIRN pre-requisite requirement.
- iii) Contractor shall co-ordinate with M/s CAIRN and take Work permit on daily basis. In this regard, contractor shall depute their representative for the same purpose.
- iv) Contractor shall arrange the pass for Vehicle entry, material entry pass from M/s CAIRN for execution of work.

If Contractor doesn't follow the Instructions as shown above then no work will be done at site. Contractor shall be responsible for the same.

AS BUILT DOCUMENT

On successful completion of testing, the Contractor shall prepare As Built drawings / reports for entire pipeline/piping system as specified in scope of work. All "As Built" drawings / reports shall be submitted as below.

- All piping GA drawings and supports at terminals
- All Support & Structure drawings
- All piping line history sheets
- Installation and testing reports.
- All Test reports, IRN's for procured materials
- All purchase specification and procurement documents.

After completion of construction & commissioning of Terminal, contractor shall incorporate all the correction in drawings, prepare and issue all the "As-built drawings" to the owner as final submission of drawings.

For final submission only 4 sets of documents plus the original transparencies shall be handed over by the contractor. Any construction done by the contractor without duly approved by the drawings shall be wholly at risk and cost Contractor shall also submit soft copy of pipe book in excel along with hard copy. Soft copy of all as-built drawings shall be also submitted in AutoCAD. Videography/ photograph of all major activities/ milestone achieved shall also be arranged and submitted by the contractor. For details of documentation to be submitted for mainline and terminal refer "Specification for pipeline construction" enclosed elsewhere with tender.

Scope of Work for Construction & Laying of Fire water Network inside the GAIL Terminal at Suveli.	Doc No.	Rev	 Page 17 of 86
	GAIL-RFP-GN-DOC-SW-001	0	
	Page 15 of 15		



GAIL INDIA LIMITED

**CONSTRUCTION & LAYING OF FIRE WATER NETWORK INSIDE THE
GAIL TERMINAL AT SUVELI**

DESIGN CRITERIA

GAIL-RFP-GN-DOC-DB-001

Rev	Date	Purpose	Prepared By	Checked By	Approved By
0	25.08.2020	Issued For Bid	SR	TR	SB



TABLE OF CONTENTS

TABLE OF CONTENTS 2

1. INTRODUCTION..... 3

2. DESIGN CRITERIA 3

3. METROLOGICAL DATA AT SITE 4

4. STATUTORY REGULATIONS, LICENCES & PERMITS 6

1. INTRODUCTION

GAIL (India) Limited, the largest state-owned natural gas processing and distribution company and the youngest Maharatna company. GAIL is the nodal agency for transportation and supply of Natural Gas to various potential customers. The receipt of gas from the sources and its transportation and distribution is intended to be by means of a high-pressure trunk transmission gas grid from the gas receiving point to various customer stations.

GAIL intend to install Firefighting water spray system as per OISD & PNGRB requirements. Work shall include all the piping, Valves, Fittings and Flanges, Double head fire hydrant and Active monitor etc.

Lyons Engineering Private Limited (LEPL) has been appointed as Engineering & Project Management Consultant by GAIL for the project.

2.0 DESIGN CRITERIA

2.1 Codes and Standards:

STANDARDS

2.1.1 All materials, equipments, Hydrant, Active monitors, piping, valves, fittings etc. dimensional standards, tolerance, prices of manufacture and testing procedure shall be in accordance with the latest revision of relevant Indian, British, American standards wherever applicable.

2.1.2 The material used and equipment supplied shall be new and the best of their kind and shall comply with the latest revisions of all relevant standards. The tenderer shall indicate in his tender the relevant standards to which the equipment, piping, fittings, etc. offered by him shall comply with. The latest revisions of applicable standards indicated in the technical specification shall be used for the design, manufacture, inspecting and testing of the items covered in this specification. The following codes and standards shall be considered for design: -

- OISD-113: Classification of areas for electrical installations at hydrocarbon processing and handling facilities.
- OISD-117: Fire Protection Facilities for Petroleum Depots, Terminals and Lube Oil Installations.
- OISD-163: Process control room safety.
- OISD – 226 & OISD - 116
- National fire protection association, USA (NFPA) codes-2001
- Standard for installation of centrifugal pumps (NFPA-20)
- Standard for water spray systems (NFPA- 15)
- Standard for sprinkler systems (NFPA-13)
- API-25 10 A: Fire protection considerations for design and operation of LPG storage

Design Basis for Construction & Laying of Fire water Network inside the GAIL Terminal at Suveli.	Doc No.	Rev	 Page 20 of 86
	GAIL-RFP-GN-DOC-DB-001	0	
Page 3 of 6			

facilities.

- Auto start system with bypass arrangement for jockey pumps in case of pressure drop in the fire hydrant line.
- Foam and Dry Chemical Power extinguishers of capacity as per SOR shall also be provided and located along with other fire fitting facilities.
- Standard for Horizontal Centrifugal Pumps for clear, cold, fresh water IS: 1520-1980
- Technical requirement for roto-dynamic special purpose pumps IS: 5120-1971
- Horizontal Centrifugal self priming pumps IS:8418-1977
- Code of acceptance tests for centrifugal, mixed flow and axial flow pumps IS: 9137-1978, BS-5316-latest edition, ISO-2548-1973
- Technical specification for centrifugal pumps ISO:9908-1993
- End suction centrifugal pumps ISO: 2858-1995
- Single faced sluice gates IS:3042-1965
- Single faced cast iron thimble mounted sluice gates IS:13349-1992
- Sluice valves for water works purpose (50-300mm size) IS: 780-1984
- Copper alloy gate, globe and check valves for general purpose. IS:778-1984
- Specification for cast iron check valves BS 5153-1991
- Foot valves for water works purposes IS:4038-1986
- Landing valves IS:5290-1993
- Valve inspection & test IS:6157-1981
- Specification for inspection and test of steel valves BS:6755-1986
- Mild steel tubes, tubular and other wrought iron fittings IS:1239, part-1-1990 & Part-2-1992
- Seamless or electrically welded steel pipes for water, gas and sewage IS:3589-1991
- Steel pipe flanges for water, oil, steam etc. IS:6392-1971
- Butt welded fittings ANSI B16.9
- Circular flanges for pipes, valves and fittings BS1560-latest editions
- Code for pressure piping ANSI B31.1
- Steel pipe flanges ANSI B 16.5
- Code of practice for laying of electrically welded steel pipes for water supply IS:5822-1994
- Excavation work-code of safety IS: 3764-1992
- Criteria for design of anchor blocks for penstock with expansion joints IS:5330-1984
- Covered electrode for manual metal arc welding of carbon and carbon manganese steel IS:814-1991
- Approved tests for welding procedure IS: 7307 (Part-I)-1974

Design Basis for Construction & Laying of Fire water Network inside the GAIL Terminal at Suveli.	Doc No.	Rev	 Page 21 of 86
	GAIL-RFP-GN-DOC-DB-001	0	
	Page 4 of 6		

- Approved tests for welders working to approved welding procedures IS:7310(Part-I)-1974
- Specification for arc welding of carbon and carbon manganese steels BS:5135-1984
- Code of practice for coating & wrapping IS:10221
- Code of practice for radiographic testing IS:2595-1978
- Recommended practice for radiographic inspection of fusion welded butt joints in steel pipes IS:4853-1982
- Recommended practice for radiographic inspection of fusion welded butt joints in steel pipes IS:1182-1983
- Safety code for industrial radiographic practice IS:2598-1966
- Ready mixed paint, stoving, red-oxide-zinc chrome priming IS:2074-1992
- Code of practice for painting of ferrous metals in building IS:1477-1971
- Colors for ready mixed paints and enamels IS: 5-1994
- Steel for general structural purposes IS:2062-1992
- Fire safety of industrial building: electrical generating & distributing stations IS 3034:1993

3 METROLOGICAL DATA OF SITE

The fire protection systems shall be designed taking into account the meteorological data prevailing at the project site as mentioned below.

Temperature

Minimum - (-) 5° C

Maximum - 55° C

Relative Humidity

Maximum - 50%

Rainfall - 25mm

Wind Velocity - Maximum – 100 Km/Hr

Environment - Dry & Hot (Desert Condition)

4 STATUTORY REGULATIONS, LICENCES & PERMITS

4.1 The contractor shall adhere to all applicable statutory requirements including TAC, OISD, Inspectorate of Factories, Indian Electricity Rules and other statutes of Govt. of India and state government. The contractor shall himself ascertain all applicable requisite regulations.

4.2 The contractor shall be solely responsible for obtaining necessary clearances from various statutory bodies including those of Govt. of India / State Govt. and as applicable during the

Design Basis for Construction & Laying of Fire water Network inside the GAIL Terminal at Suveli.	Doc No.	Rev	 Page 22 of 86
	GAIL-RFP-GN-DOC-DB-001	0	
Page 5 of 6			

course of manufacture/ fabrication, testing, transportation and delivery of plant and equipment. The rates quoted in this connection shall be deemed to include any fees payable to Govt./ Fire Authorities/ Statutory bodies for obtaining approval.

4.3 Contractor shall keep constant liaison with the local Fire Authority, Electrical Authority and all other Statutory Authorities whose approval and permissions/ sanctions before and after execution of the work are required to be obtained.

4.4 It shall be the Contractor's responsibility to obtain the approvals and permissions, sanctions, No Objection certificates from relevant Fire Authorities for work done by him to enable owner to take up the operation of plant. Contractor shall comply with all requirements of the appropriate authorities, submit documents, test reports and conduct such tests as may be required by the concerned authority to its full satisfaction.

Design Basis for Construction & Laying of Fire water Network inside the GAIL Terminal at Suveli.	Doc No.	Rev	 Page 23 of 86
	GAIL-RFP-GN-DOC-DB-001	0	
	Page 6 of 6		

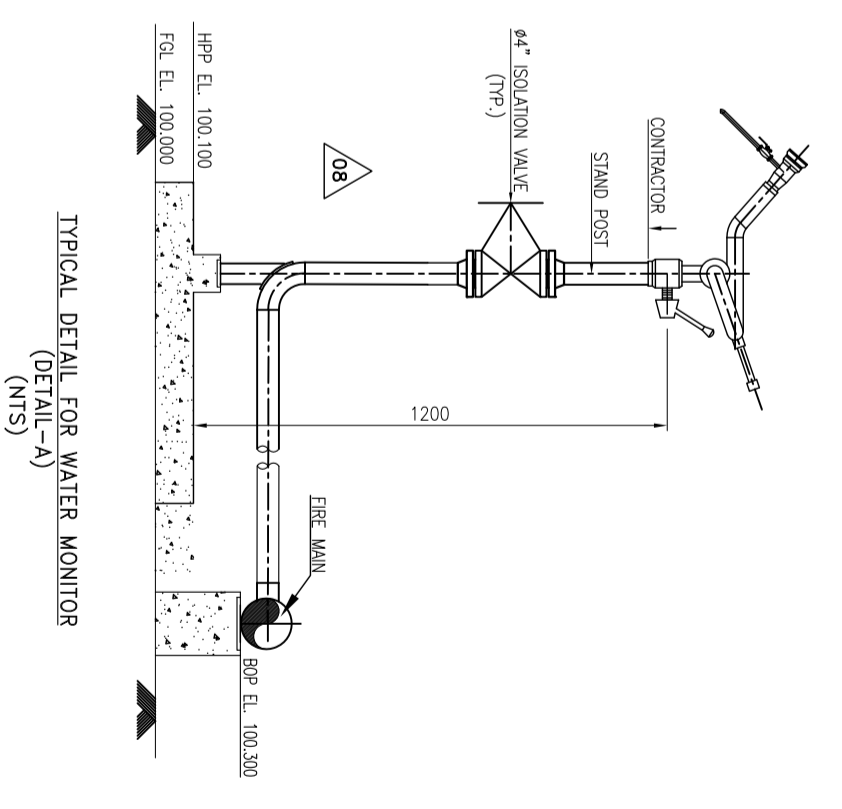
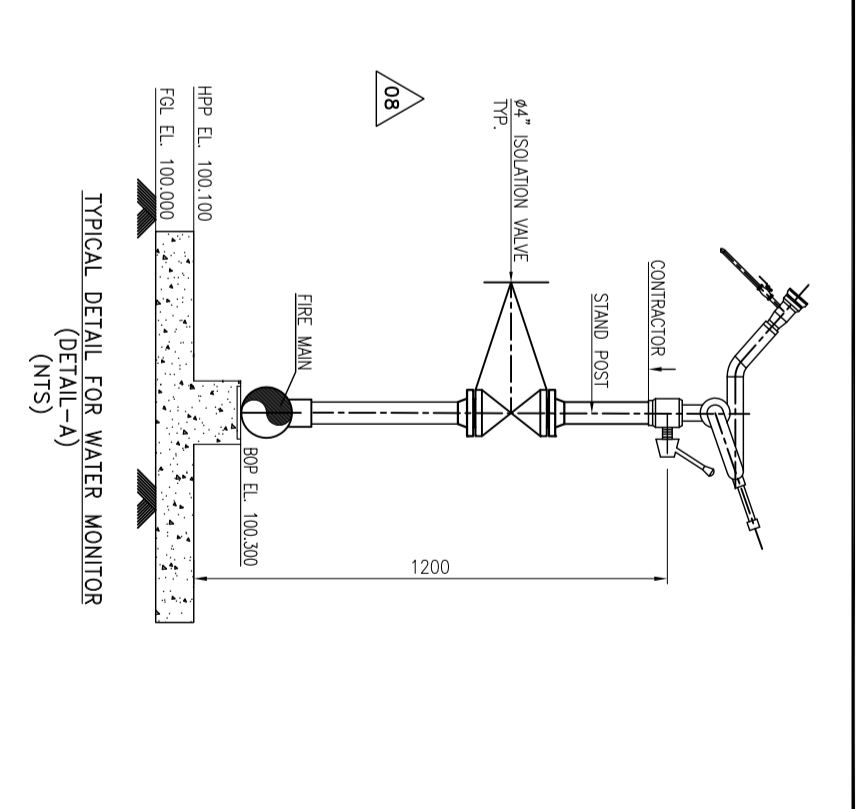
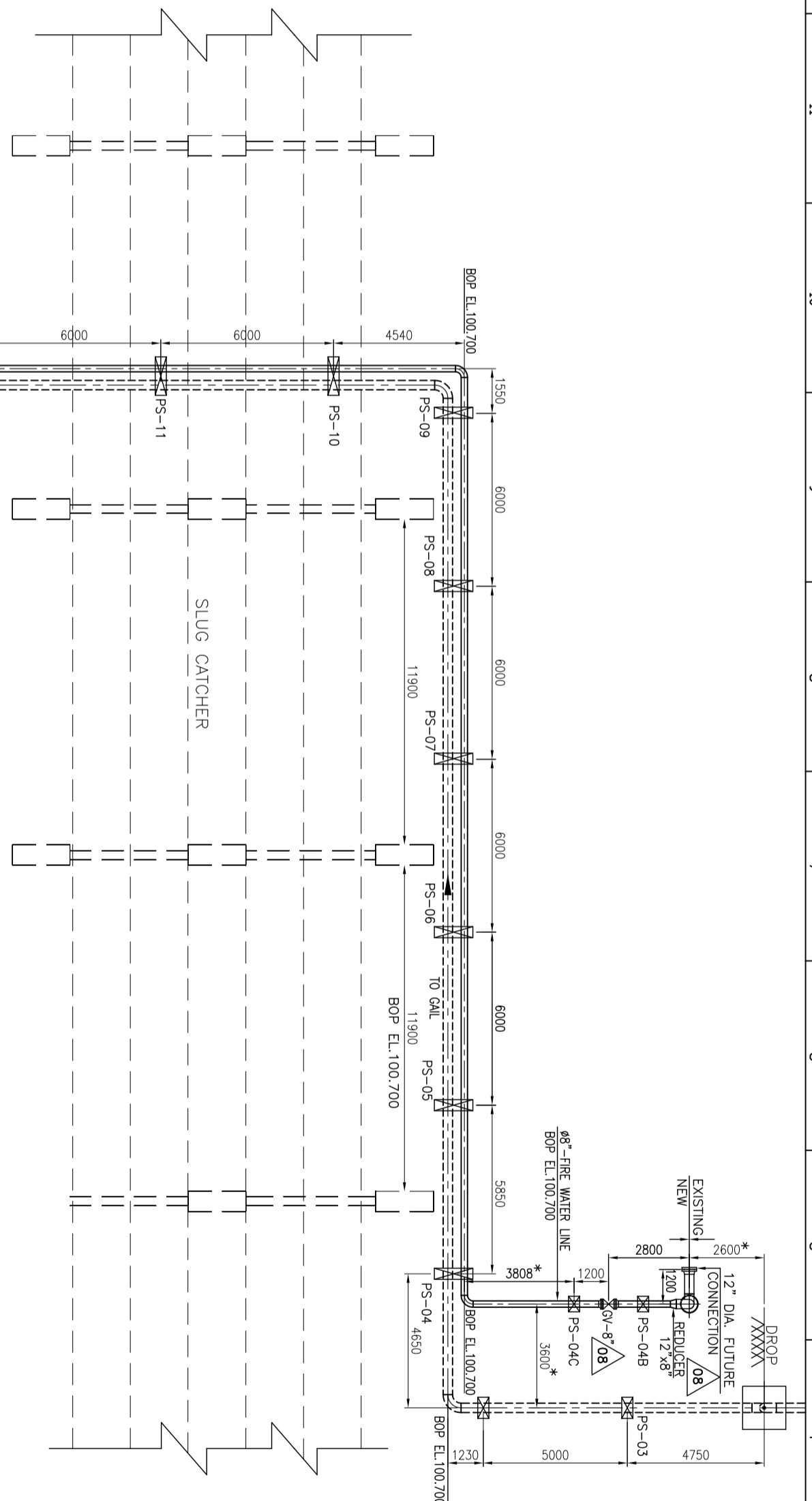
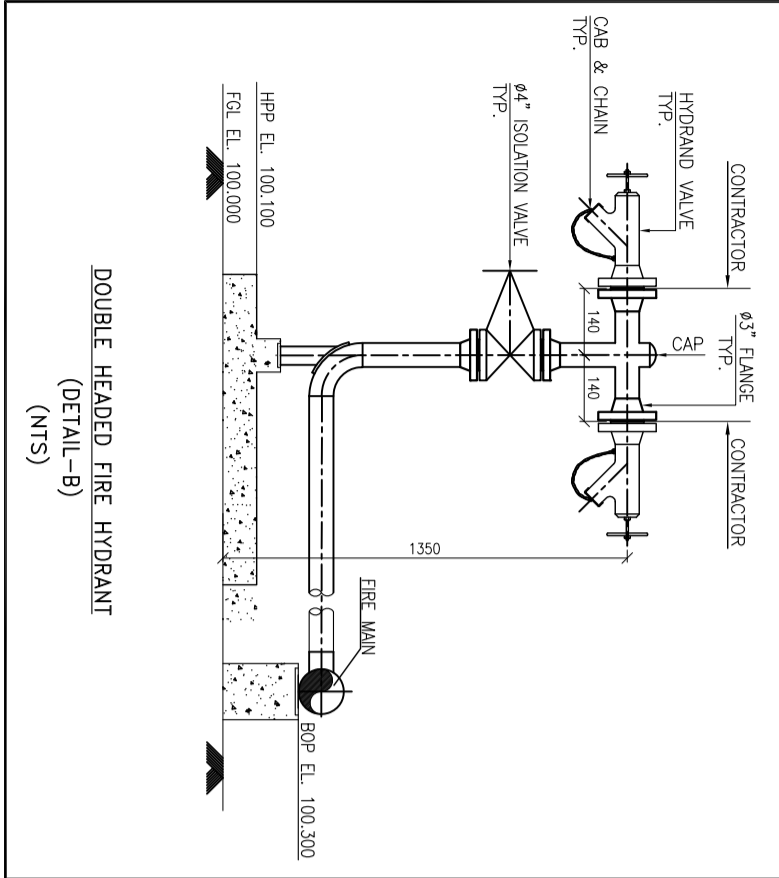
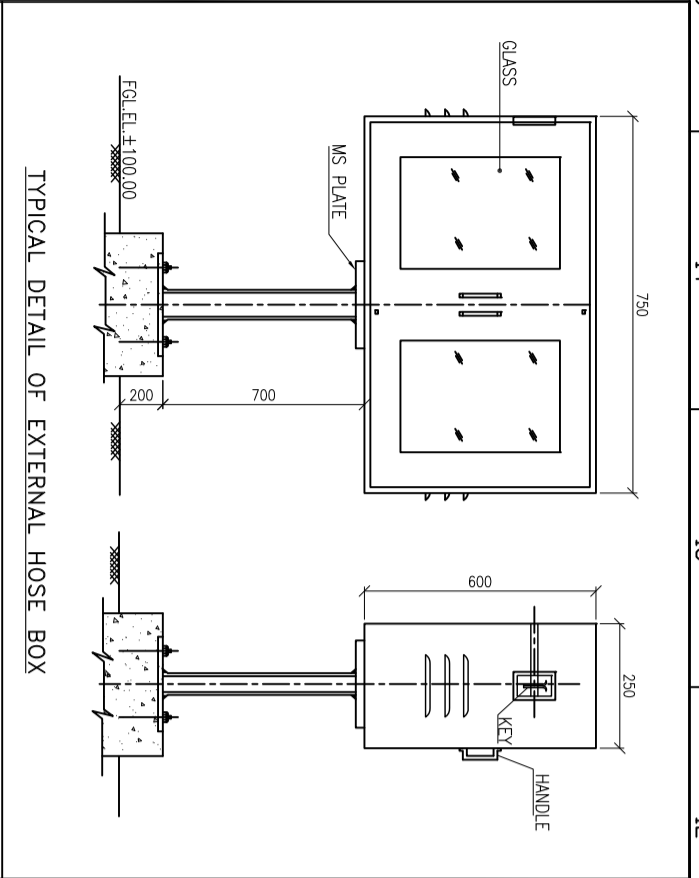
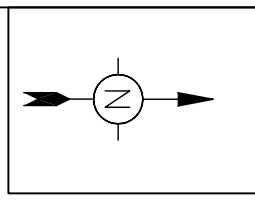

REFERENCE DRAWINGS / DOCUMENTS	
S.NO.	DRAWING TITLE
1.	PLOT PLAN SUVELI 02541-CD-PL-PP-0019
2.	METERING SKID TFG-170007-GAD-SKID-5

- NOTES:-**
- ALL DIMENSION ARE IN MM AND CO-ORDINATES AND LEVELS ARE IN METERS UNLESS OTHERWISE SPECIFIED.
 - REFERENCE LEVEL + 100.00 MTR. CORRESPONDS TO EXISTING FINISHED GROUND LEVEL (F.G.L).
 - ALL FIRE FIGHTING EQUIPMENT SHALL BE IS/IAE APPROVED.
 - ALL U/G PRELIME SHALL BE PROVIDED WITH DOUBLE WRAPPING & COATING AS PER IS:10221.
 - ALL FIRE WATER LINES CROSSING UNDER ROADS, APPROACH ROADS SHALL BE Laid WITH 150MM WATER FROM ROAD TOP LEVEL.
 - ABOVE GROUND FIRE WATER PIPES SHALL BE PAINTED FIRE RED TO SHADE NO. 536.
 - ABOVE GROUND PIPING SHALL BE SUPPORTED ON RCC SLEEPERS AT 6.0M MAXIMUM SPACING.
 - TO AVOID FOLLING WITH THE EXISTING A/G & U/G FACILITIES, FIRE WATER PIPE SHALL BE LOWERED WHEREVER REQUIRED.
 - DIMENSION MEASURED IN THE DRAWING AREA INDICATIVE SHOULD BE ADJUSTED AT SITE DEPENDING UPON ANY FOLLING.
 - THE WATER BELOW GROUND LEVEL SHALL BE PROTECTED WITH PIPE SLEEVES AT ROAD CROSSING.
 - ALL HYDROSTATIC DRAN & VENT POINTS TO BE PLUG & SEAL WELD AFTER HYDR TESTING.
 - DRAIN POINT SHALL BE PROVIDED BASED ON CONTRACTOR HYDRO TESTING SPOOLS.
 - SUPPORT SHALL BE AS PER DWG. NO.-00005-PL-CV-DR-004.
 - THIS DIMENSION BETWEEN SITE SUPPORT SHALL BE VERIFIED AT DURING CONSTRUCTION.
 - EXISTING SUPPORT TO BE USED FOR LAYING NEW PIPE.
 - ALL FIRE MONITORS & HYDRANTS SHALL BE MIN. 15 MTR. AWAY FROM PROGRESS EQUIPMENTS.
 - MINIMUM EFFECTIVE RANGE OF FIRE WATER MONITOR SHOULD NOT BE LESS THAN 30M.
 - FIRE AS PER SITE CONDITION.
 - FIRE MONITORS & HYDRANTS SHALL BE FINIALIZED AS PER SITE CONDITION AT SUITABLE LOCATION.

LEGEND:-

	PIPE SUPPORT		SPECTACLE BLIND
	FINISHED GROUND LEVEL		CENTER LINE
	PIPE SUPPORT		GAS PIPELINE
	PIPE GUIDE SUPPORT		PROPOSED FIRE WATER LINE
	ABOVE GROUND		WATER MONITOR
	UNDER GROUND		DELUGE VALVE (NEW)
	BOP		FLANGED GATE VALVE
	HPP		
	HEIGHT PAVEMENT POINT		

S.No.	DESCRIPTION	CAPACITY (LPM)
1	FIRE MONITOR	2400 LPM
2	FIRE HYDRANT	600 LPM PER OUTLET

REV.	DATE	DESCRIPTION	PREP/CHKD	APPD.
0	06.03.19	ISSUED FOR REVIEW	DK	SH
1	03.04.19	RE-ISSUED FOR REVIEW	DK	SH
2	24.04.19	RE-ISSUED FOR REVIEW	DK	SH
3	25.07.19	RE-ISSUED FOR REVIEW	DK	SH
4	04.01.20	RE-ISSUED FOR REVIEW	DK	SH
5	18.03.20	RE-ISSUED FOR REVIEW	DK	SH
6	28.03.20	REVISED AS PER LATEST REQUIREMENTS	DK	SH
7	17.07.20	REVISD AS PER REQUIREMENTS	DK	SH
8	10.08.20	REVISED AS PER REQUIREMENTS	DK	SH

OWNER
GAIL (India) Limited.
A GOVT. OF INDIA UNDERTAKING

PMC
Ms. VCS QUALITY SERVICES PVT. LTD.

PROJECT			
GAIL TIE-IN CONNECTIVITY SUVELI			
SCALE	TITLE	CLIENT JOB NO.	DRAWING NUMBER
1:125	FIRE WATER PIPING GAD FOR CAIRN SUVELI	00005	00005-PL-FW-DR-001
SIZE	CLIENT JOB NO.	DRAWING NUMBER	SHEET
A1	00005	00005-PL-FW-DR-001	1 OF 1
REV.	REV.	REV.	REV.
			8

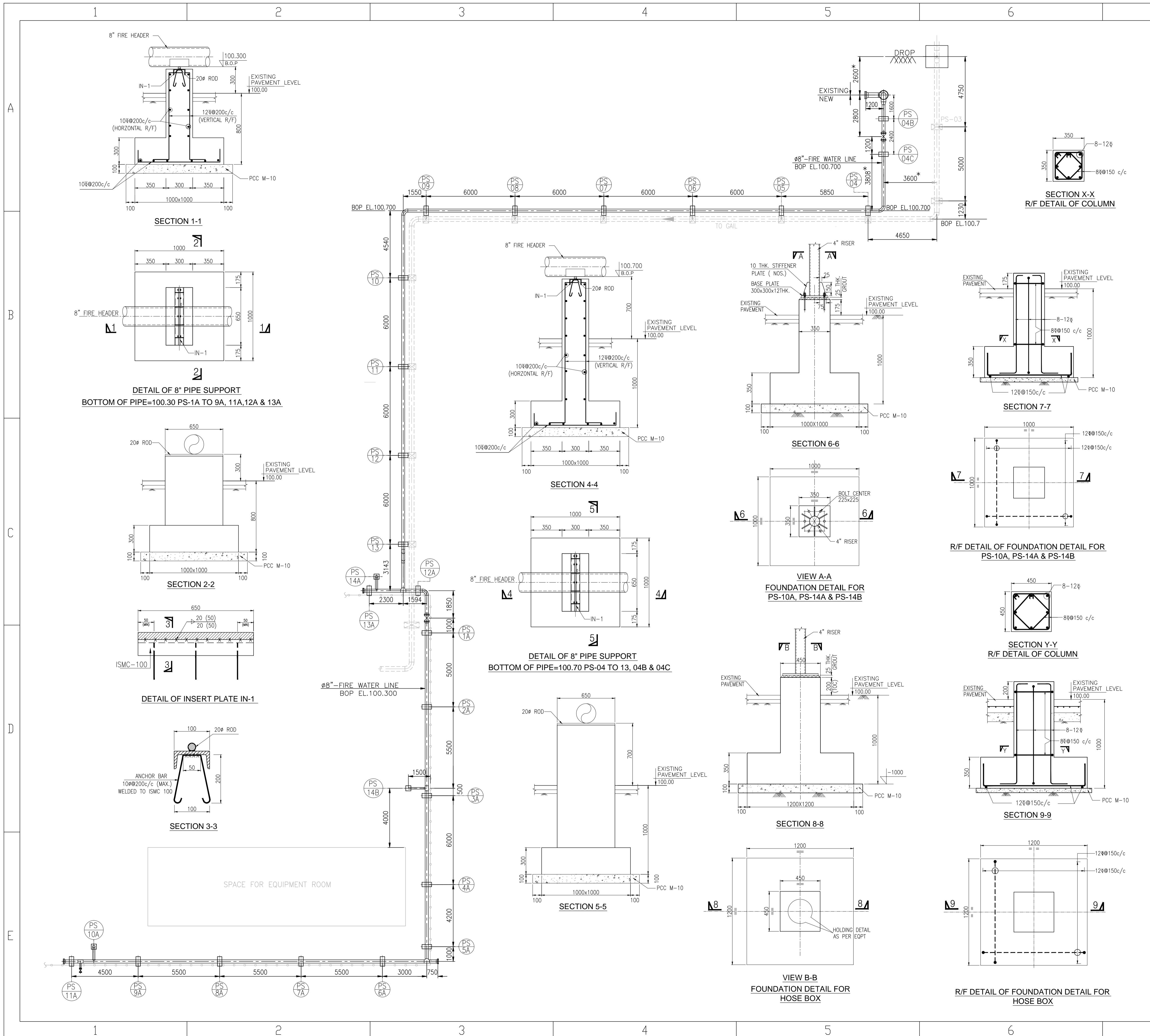

REFERENCE DOCUMENTS NO.																
FIRE WATER PIPING GAD FOR CAIRN SUVELI		00005-PL-FW-DR-001 R-8														
NOTES																
1. ALL DIMENSIONS ARE IN mm. AND LEVELS ARE IN METER. (UNLESS MENTIONED OTHERWISE)																
2. FOLLOW WRITTEN DIMENSIONS ONLY & DO NOT SCALE																
3. REFERENCE LEVEL 100.00 MTR. CORRESPONDS TO THE EXISTING FINISHED GROUND LEVEL (F.G.L).																
4. GRADE OF CONCRETE FOR RCC WORKS SHALL BE M25 & PCC SHALL BE M-10. CONFORMING TO IS:456 UNLESS NOTED OTHERWISE.																
5. ALL REINFORCEMENT BARS SHALL BE Fe-500D CONFORMING TO IS:1786.																
6. CLEAR COVER TO REINFORCEMENT SHALL BE FOLLOWS. (i) FOOTING = 50 mm (ii) PEDESTAL = 40 mm																
<table border="1"> <tr> <td>0</td> <td>05.09.20</td> <td>ISSUED FOR REVIEW & COMMENTS</td> <td>DV</td> <td>HM</td> <td>HM</td> </tr> <tr> <td>REV.</td> <td>DATE</td> <td>DESCRIPTION</td> <td>PREP.</td> <td>CHKD.</td> <td>APPD.</td> </tr> </table>					0	05.09.20	ISSUED FOR REVIEW & COMMENTS	DV	HM	HM	REV.	DATE	DESCRIPTION	PREP.	CHKD.	APPD.
0	05.09.20	ISSUED FOR REVIEW & COMMENTS	DV	HM	HM											
REV.	DATE	DESCRIPTION	PREP.	CHKD.	APPD.											
CLIENT:		GAIL (INDIA) LIMITED														
PMC:		LYONS ENGINEERING PVT. LTD.														
PROJECT:		GAIL TIE-IN CONNECTIVITI SUVELI														
SCALE	TITLE: STRUCTURAL DETAILS OF PIPE SUPPORT FOR CAIRN SUVELI															
NTS																
SIZE	JOB NO.	DRAWING NUMBER	SHEET	REV.												
A2	035	STD-CV-DWG-PS-001	1 OF 1	0												



GAIL INDIA LIMITED

**CONSTRUCTION & LAYING OF FIRE WATER NETWORK INSIDE THE
GAIL TERMINAL AT SUVELI**

TECHNICAL SPECIFICATION FOR FIRE FIGHTING SYSTEM

GAIL-STD-FF-DOC-TS-001

0	25.08.2020	Issued as Standard Specification	SR	TR	SB	
Rev	Date	Purpose	Prepared By	Checked By	Approved By	

ABBREVIATIONS:

- ASME : American Society of Mechanical Engineers
- ASTM : American Society for Testing and Materials
- API : American Petroleum Institute
- BHN : Brinell hardness number
- HAZ : Heat Affected Zone
- MSS-SP : Manufacturers Standardization Society - Standard Practice
- RTJ : Ring Type Joint
- SSPC : Steel Structures Painting Council
- CE : Carbon Equivalent
- LPG : Liquefied Petroleum Gas

TABLE OF CONTENTS

TABLE OF CONTENTS 3

1. GENERAL..... 3

2. CODES 3

3. SCOPE..... 3

4. FIRE FIGHTING EQUIPMENTS(MECHANICAL WORKS)..... 3

5. CIVIL& STRUCTURAL WORKS 10

1.0 GENERAL

This specification lays down the broad technical specification for the Fire Fighting system to be provided for various areas as specified in SOR, specifications.

2.0 CODES AND STANDARDS

The following codes and standards shall be followed for deluge valve:

1. Rules for automatic sprinkler installation published by TAC.
2. Applicable ISI codes
3. NFPA guidelines

3.0 SCOPE

This specification covers design, supply, fabrication, erection, testing and commissioning Complete with all mechanical and electrical items as elaborated in the following paragraphs. The system shall consist of the following as mechanical part of the system.

- Piping for Water, pipe support, flanges etc.
- Medium velocity spray nozzles or Hose pipes or nozzle
- Fittings and Gate Valve etc.

4.0 FIRE FIGHTING EQUIPMENTS (MECHANICAL WORKS)

A well-designed Hydrant system is the backbone of entire firefighting system as it fights fire of all classes of risks. The entire terminal is covered with water based fire hydrant network. For the purpose of hydrant system design, the MS has been considered as medium Hazard occupancy as per TAC classification. The designed main consist of MS coated /DI pipes, Distribution mains form ring around each unit, which is connected to the ring main running in the vicinity, which mainly consist of fire water storage facility, existing main fire pumps, existing jockeys pumps, double outlet landing valves, monitors etc. The work shall be carried out as per OISD: 214.

Water to the hydrant network supplied by existing pumps exclusively envisaged for firefighting purpose.

The fire water network lines shall be continuously kept pressurized at 9.5 kg/cm² (g) (at the hydraulically remotest point of application).

The following firefighting items shall be loose supplied by contractor.

a) Fire-water mains shall be equipped with double headed hydrants to which hoses can be connected. Each hydrant shall be provided with a hose box equipped with two numbers of standard fire hose and multipurpose foam cum water spray nozzle. Fire hoses and hose nozzles shall be as ISI marked/UL Listed.

f) Active Monitors shall be water monitor and water cum foam type.

c) Fire water cum foam monitors equipped with foam pick up tube and foam drum shall be used for supplying foam concentrate to the fire water cum foam monitors. In order to replenish the drums as and when required, Manual valves along with foam connection line shall be provided

Technical specification for Fire Fighting system works	Doc No.	Rev	 Page 29 of 86
	GAIL-STD-FF-DOC-TS-001	0	
	Page 4 of 15		

in the foam concentrate header, near the fire water cum foam monitors. This foam replenishment arrangement shall be done by other mechanical installation contractor. Fire water cum foam monitors and Water monitor shall be UL Listed / FM Approved.

- d) Each ILBP system assembly contain all necessary components including Foam Proportioner, Pressure balancing spool valve, Duplex gauge (or Two separate pressure gauges), Control valves, drain valves, check valves, and Interconnecting Brass Pipe.
- e) Two way fire brigade connections shall be provided.
- f) Trailer pump Connectors (TPC) shall be provided.
- g) Fire hose reel with stand shall be supplied

4.1 GENERAL ACCESSORIES

- a) Complete equipment, piping, fittings, valves, instruments and controls, Supports, structures etc.
- b) Shop inspection and testing, Factory Acceptance Tests (FAT), Site Acceptance Test (SAT)
- c) Packing, marking and forwarding.
- d) Spares and Special tools.
- e) Guarantee to Meet all HAZOP, SIL and Safety Operational Requirement, Contractor shall carry out the design and engineering of the Fire Fighting package in accordance with International codes & standards, local legislation, Specification & Design basis attached in the subsequent sections.

4.1.1 ISOLATION VALVES

To obtain a safe isolation, it is required to utilize valves which provides good isolation and keeps the integrity towards the live process. The following valve types shall be considered to give sufficient integrity as isolation valve in the facility

Gate valves can be used as isolation valves in water system only. Produced water shall be considered as hydrocarbon system i.e. butterfly valves shall not be used as isolation valves. Butterfly valves shall also not be used as isolation valves in heating medium system (even if the heating medium is fresh water) or in steam system (even in the condensate return lines). For safety reasons, certain block valves shall be designated 'Locked open'(LO) or 'Locked closed'(LC) on the P & IDs. Isolation valves shall be locked in position only if inadvertent operation of the valve would lead to damage to equipment or an unsafe condition.

4.1.2 Technical specification for valves:

The valves & sluice gates shall be designed, manufactured and tested as per relevant Indian Standards or as per other International standards acceptable to the Purchaser and will be suitable for the duty conditions specified below. All underground valves will be provided with valve chambers with RCC covers. The size of chambers shall be suitable for easy Maintenance of the valve. Complete civil work for this is in the contractor's scope.

Technical specification for Fire Fighting system works	Doc No.	Rev	
	GAIL-STD-FF-DOC-TS-001	0	
	Page 5 of 15		

S.No.	Items	Nominal Dia.(mm)	Specifications
1	Isolation Valve	Below 50	Forged Carbon steel gate valve, screwed as per API – 602 standard class 800 # ASTM A-105, trim 13% Cr, Bolt/Nut – B7/2H, Socket end threading as per ANSI B.16.11 Gasket SPW S.S. 304 with CAF Hand Wheel - Cast steel
		50 to 300	Cast Carbon Steel flanged gate valve as per standard API-600 class150 # , Body & bonnet material ASTM A 216 Gr. WCB, Trim 13% Cr S.S, Spindle & Gland bush – A1S1 410. Hand wheel C.S, Gasket SW S.S-304 + LAF, flange drilled to ANSI – B.16.5 along with companion WNRF welded flange (without hub) drilled as per B.16.5 and gasket, Nut & bolt etc. Hand Wheel - C.S.

4.2 PIPING :

Above ground fire water pipes shall be painted fire red confirming to shade no. 536 of IS:5.

All fire water piping shall be hydro tested to a pressure of 18 Kg/cm². Adequate nos. of isolation valves in the fire water network shall be provided over and above already provided, if so required to ensure easy maintenance at the affected part of the network and at the same time uninterrupted water supply to the rest of the network for firefighting remains available.

TECHNICAL SPECIFICATION FOR PIPES, VALVES & FITTINGS:

Pipes and pipe fittings in general shall comply with the requirements of BIS codes and TAC norm. The pipes shall be manufactured / supplied as specified below:

- i) Upto 150 mm nominal sizes : Pipes conforming to IS-1239- 1984 Part-I (heavy grade) With Plain ends.
- ii) 200 mm to 400 mm size - Pipes conforming to IS-3589 -1973 but thickness as specified below

Nominal Dia O.D X Thickness in mm

DN 200 mm : 219.1 x 6.35

DN 250 mm : 273.0 x 7.14

DN 300 mm : 323.9 x 7.14
 DN 350 mm : 355.6 x 7.14
 DN 400 mm : 406.4 x 7.14

4.2.2 Technical Specifications for Pipes and valves for Spray system :

The material of construction and manufacturing standard of pipes, fittings, valves, fasteners, gaskets, etc. shall be as described in table-1 below:-

S.No.	Items	Nominal Dia.(mm)	Specifications
1.	Pipe	65 and below 80 100 to 150 200 to 250 250 and above	IS-1239 (Part-1) - '90 Heavy, IS-1239 (Part-1) - '90 Heavy, IS-1239 (Part-1) - '90 Heavy, IS-3589 Gr.410 pipe commercial quality or equivalent. Thickness as specified.
2.	Pipe fittings		A 234 Gr. IS-1239/3589/2062
2.1	Screwed fittings	65 & below	IS-1239 (Part-1) - 90 Galvanized
2.2	Fabricated fittings		
	Bends	150 and above	Mitered bends with radius 1.5 DN from black pipe.
	Tees/Crosses	150 and above	Fabricated from black pipes by smithing.
	Reducers	150 and above	Fabricated from black pipes by taper cutting and welding.
3	Bolting	All sizes	IS – 1367
4	Gaskets	All sizes	Spiral wounded graphite filled gasket as per B 16.5, 150 #, ASTM A-105, WNRF.
5	Flanges	All sizes	WNRF flanges to IS-6392 - `71 machined from Carbon Steel plates to IS-2002-`92 Gd. 2 with bore to suit pipe O.D.

Fittings shall be supplied as per IS: 1239-1992 Part II for pipes up to 150 mm dia and shall be fabricated from pipes for dia 200 mm and above.

4.3 Pipe Support :

4.3.1 All pipe clamps and support shall be galvanized steel. When fabricated from M.S. steel sections, the supports shall be factory galvanized before use at Site. Welding of galvanized clamps and supports will not be permitted.

4.2.3 Hangers and supports shall be capable of carrying the sum total of all concurrently acting loads. They shall be designed to provide the required supporting effects and allow pipelines movements as necessary. All guides, anchored, braces, dampeners, expansion joints and structural steel to be attached to the building/structure, trenches etc. shall be provided by the contractor. Hangers and components for all piping shall be approved by the consultant. Anchoring fasteners shall be rated to take minimum 2 tons load and shall be of approved make.

4.2.3 Wherever angle type supports are being used, profiled packing materials or wood or materials as approved by the Engineer shall be used. The packing materials shall be at least 25 mm thick, and tight fitted with the pipe.

4.2.4 Seismic supports shall be provided as per seismic zone # 5 as per NFPA-13.

4.4 External Hydrant :

4.4.1 Each external hydrant station shall consist of one No. Stainless Steel Single headed hydrant valve along with 2 Nos. hoses and one branch nozzle.

4.4.2 The underground piping for external hydrants shall be MS/class 'c' (heavy duty) with wrapping-coating arrangement. The maximum spacing between two external hydrant shall not be more than 45 mts.

4.4.3 One No. Two way Fire Brigade Inlet connection shall be provided for filling of existing underground Fire tank in case of emergency and in addition one No. Two way Fire Brigade connection is made to External Fire Ring Main as well as to wet riser in case fire pumps fails to start.

4.4.4 External Fire Hydrant will be provided on the ring main. Hydrant shall be located at least 2M away from the building.

4.5 Anchor Thrust Blocks:

a) Contractor shall provide suitably designed anchor blocks in cement concrete to encounter excess thrust due to water hammer & high pressure.

b) Thrust blocks shall be provided at all bends & tees & such other location as determined by the Authorized Representative.

c) Exact location, design, size and mix of the concrete block shall be approved by the Authorized Representative prior to execution of work.

4.6 Pipe Protection:

4.6.1 All pipes above ground and in exposed locations shall be painted with two coats of Red Oxide primer and two coats of synthetic enamel paint of approved shade.

4.6.2 Pipes buried below ground level shall be protected against corrosion to give a uniform with multi-layer anticorrosive treatment as per IS: 10221 by using nonwoven polyester mat of 4 mm thickness. The application of pipe coat primer and multilayer tape shall be as specified by the manufacturer.

4.7 Welding:

4.7.1 Before welding, the ends shall be cleaned by wire brushing, filing or grinding. Each weld-run shall be cleaned of slag before the next run in deposited.

4.7.2 Welding shall be done by certified welders only.

4.7.3 Welding at any joint shall be completed uninterrupted. If this cannot be followed for some reasons, the weld shall be insulated for slow and uniform cooling.

- 4.7.4 Welding shall be done by manual oxy-acetylene or manual shielded metal arc process. Automatic or semi-automatic welding processes may be done only with the specific approval of purchaser.
- 4.7.5 Socket weld joint shall be done with low hydrogen type covered electrodes with manual shielded metal arc process.
- 4.7.6 Joints between M.S. Pipes and fittings shall be made with the pipes and fittings having "V" groove and welded with electrical resistance welding in an approved manner.
- 4.7.7 Weld Electrodes shall be of one of the approved makes, of grade and type as suitable for the job and meeting the approval of the engineer.
- 4.7.8 As far as possible welding shall be carried out in flat position. If not possible, welding shall be done in a position as close to flat position as possible.
- 4.7.9 Joints shall be given a first weld in full width without burrs on the full dia of the pipe. Welding shall be carried out vertically from the surface to be welded. Weld fluxes shall not be so plastic such as to fall or drip down.
- 4.7.10 The root of butt joints shall be such as to achieve full penetration with the complete fusion of root edges. The weld projection shall not exceed 3 mm inside the pipe.
- 4.7.11 After application of first coat the weld shall be ground and then another layer of welding shall take place. The weld shall also be cleaned by grinding.
- 4.7.12 For pipes with wall thickness less than 3 mm, oxy-acetylene welding is recommended.
- 4.7.13 All pipe cutting shall be by oxy acetylene gas cutting only. The cut surface shall be cleaned and ground by an electric grinder before further welding.
- 4.7.14 Pipe cutting or welding in inaccessible areas shall be avoided. Pipes shall not welded in trenches unless the bottom edge of the pipe does not have clear space for working with electrode.
- 4.7.15 Fillet welds shall be made by shielded metal arc process regardless of thickness and class of piping. Electrode size shall not exceed 10 SWG (3.25 mm). At least two runs shall be made on socket weld joints.
- 4.7.16 For supports, angle pieces shall be cut by oxy acetylene gas and cleaned by electric grinder. All cutting for bolt inserts shall be by electric drill.
- 4.7.17 Tappings (nipple pieces, etc.) for Hydrant from the risers shall be fabricated separately and then welded to the riser. A tool piece of 80 mm dia or as required shall be first prepared, one end shall be cut as per profile of riser pipe on which it shall be finally welded. The other end shall have the flange welded to it. The flange holes shall be set so as to receive the hydrant head correctly. Inside of the flange shall also receive a single layer of welding. The welding shall then be cleaned with a grinder. The tool piece shall then be welded to the riser. This procedure shall also be applied for all flanges.
- 4.7.18 As a rule no backing ring shall be used for circumferential butt welds.
- 4.7.19 Welding carried out in ambient temperature of 5 Deg C or below shall be heat treated.

Technical specification for Fire Fighting system works	Doc No.	Rev	 Page 34 of 86
	GAIL-STD-FF-DOC-TS-001	0	
	Page 9 of 15		

4.8 Hose Reel:

- 4.8.1 Wall mounting the swinging type first aid hose reel with drum shall conform to IS : 884-1985.
- 4.8.2 The rubber tubing shall be 20 mm dia high pressure rubber hose 36.0 m long as per IS: 444 with gunmetal shut off nozzle having 6.5 mm dia orifice and control valve, shut off valve of approved make. The wall mounted bracket shall be fixed by means of fasteners. The hose reel shall have a gun metal nozzle.
- 4.8.3 The hose reel shall be connected directly to the riser by means of 25 mm dia MS pipe with threaded bends, union & one no. valve.
- 4.8.4 The drum can swing up to 170 degree.

4.9 Hose Cabinets:

- 4.9.1 Hose cabinet shall be fabricated from 16-gauge MS powder coated sheet of fully welded construction with hinged single/double door partially glazed door with suitable locking arrangement, stove enameled fire red paint with 'Fire Hose' written on it prominently. Glass panes shall be 4 mm thick.
- 4.9.2 The hydrant cabinet shall hold double headed hydrant, 2 nos. Hoses and 1 no. branch pipe.
- 4.9.3 The cabinet shall have two pipe studs of 200 mm dia in MS with base which shall be fixed to the back of the cabinet and shall be used to hold the RRL hose.

4.10 RRL Hoses:

- 4.10.1 The hoses for the internal and external hydrant system should be rubber impregnated woven jacketed type conforming to IS:636 Type-B. Each fire hose shall be provided with quick coupling, branch pipes, nozzles, spanners etc.
- 4.10.2 Hose pipes of all types shall be capable of withstanding an internal water pressure of not less than 35 Kg/Sq.cm without bursting. It must also withstand a pressure of 21 Kg/Sq.cm without undue leakage or sweating.
- 4.10.3 Each hose shall be fitted with instantaneous spring lock type couplings at both ends. Hose shall be fixed to the coupling ends by copper rivets and the joint shall be reinforced by 1.5 mm galvanized mild steel wires and leather bands.

4.11 Branch Pipes and Nozzle:

Stainless steel Standard Branch Pipe shall be used conforming to IS: 903 with Stainless steel nozzle of 16mm dia to fit standard instantaneous type 63mm dia hose coupling. Suitable spanners of approved design shall be provided in adequate numbers for easy assembly and dismantling of various components like branch pipes, nozzles, quick coupling ends.

4.12 Hydrant Valve:

- 4.12.1 Stainless steel Hydrant valve shall be of oblique pattern provided as per IS: 5290 complete with hand wheel, quick coupling connection, spring and blank cap and chain.
- 4.12.2 The hydrant shall have flanged inlet of 100 mm dia and 63 mm female instantaneous type outlet. The hydrant shall have a rubber plug with chain fixed to the main body of the Hydrant.

4.13 Pressure Switch:

- 4.13.1 The pressure switches shall be employed for starting and shutting down operation of pumps automatically, dictated by lines pressure. The Pressure switch shall be diaphragm type, it shall be suitable for line pressures as per requirements.
- 4.13.2 The switch shall be suitable for consistent and repeated operations without change in values.
- 4.13.3 The enclosure shall be of aluminium and pressure element and wetted parts shall be of stainless steel. The switch shall be snap acting type with 1 no. NO/NC contact.

4.14 Air Vessel:

- 4.14.1 Three air vessels shall be provided to compensate for slight loss of pressure in the System of the respective pressure zones and to provide an air cushion for counter acting pressure surges whenever the pumping set comes into operation. It shall be normally partly full of water, the remaining being filled with air, which will be under Compression when the system is in normal operation.
- 4.14.2 Air vessel shall be fabricated from MS plate conforming to IS : 2002 grade 2A having 8mm thickness shell with 10 mm thick dished ends and suitable supporting legs. It shall be provided with a 80 mm dia/100 mm dia flanged connections from pump, one 25 mm drain with ball valve and 15 mm sockets for pressure gauge and pressure switches. The air vessel shall be hydraulically tested to 30 kg/cm² pressure for 30 minutes.
- 4.14.3 The pressure vessel shall be provided for hydrant and sprinkler system. The pressure switches shall be mounted on the header of each air vessel. The air vessel shall also be provided with safety valve mounted at the top.

4.15 Testing :

- 4.15.1 All piping in the system shall be tested to hydrostatic pressure of 13.5 Kg/Sq.cm without drop in pressure for atleast 2 hours.
- 4.15.2 Rectify all leakages, make adjustments and retest as required and directed.

4.16 PAINT SYSTEMS

The paint system should be selected based on the areas classified inside the plant as given below. The Geographical corrosive and highly corrosive conditions of a plant located in Coastal and Marine area, Highly Corrosive conditions inside a plant and Industrial Corrosive Environment are taken care in the specifications in total.

Technical specification for Fire Fighting system works	Doc No.	Rev	 Page 36 of 86
	GAIL-STD-FF-DOC-TS-001	0	
	Page 11 of 15		

ENVIRONMENT/AREA CLASSIFICATION

- Corrosive Environment-Offsite areas (excluding Cooling Tower area, DM-plant)
- Corrosive Environment-Unit areas
- Highly Corrosive Environment-Unit & Offsite areas of a plant with corrosive fumes like HCL, H2S04, Water impingement, Salty water, Chloride and water mist, Cooling Tower areas, DM Plant area.

Notes:

1. Painting systems (Primers, Finish Paints etc) based upon Area classification/ Environments (Corrosive / Highly Corrosive) / Applications are tabulated in Tables 8.0 to 17.0.
2. Primers & Finish paints covered in Tables 8.0 to 17 .0 are listed in Table 7.1.
3. Repair of Pre-Erection/Pre-Fabrication &Shop priming after erection/welding shall be done as per Table 7. 2.

TABLE 7.1: LIST OF PRIMERS & FINISH COATS :

PRIMERS

- P-2 Chlorinated rubber zinc Phosphate Primer
- P-4 Etch Primer/Wash Primer
- P-6 Two component Epoxy Zinc Phosphate Primer cured with polyamine hardner
- P-7 Single pack, synthetic resin based 'ZINGA' zinc primer containing 96% of electrolytic zinc dust in dry film

FINISH COATS/PAINTS

- F-2 Two component Acrylic — Polyurethane finish paint.
- F-3 Chlorinated Rubber finish paint.
- F-6A High Build Epoxy finish coating cured with polyamine hardner.
- F-6B High Build Epoxy finish coating cured with polyamide hardner.
- F-7 High build coal tar epoxy coating cured with polyamine hardner.
- F-8 Self priming surface Tolerant High Build epoxy coating cured with polyamine hardner.
- F-9 Two component Inorganic Zinc Silicate coating.
- F-11 Heat resistant synthetic medium based Aluminium paint.
- F-12 Two component Heat resistant Silicone Aluminium paint.
- F-14 Specially formulated coal tar epoxy coating cured with polyamine hardner.
- F-15 Two component Epoxy phenolic coating cured with Polyamine adduct hardner system.
- F-16 Engineered Epoxy poly Siloxane Coating or high build cold applied inorganic co-polymer based aluminium coating.
- F-17 Two component solvent free type high build epoxy phenolic/novalac epoxy phenolic coating cured with Polyamine adduct hardner system.

4.17 PIPING COLOUR CODE

The following colour coding system has been made based on international standards like ASME/ ANSI, BS and Indian Standard.

5.0 CIVIL & STRUCTURAL WORKS

All materials as elaborated in respective SOR and scope of work enclosed as Annexure-I elsewhere with the tender.

The scope of work to be performed under this contract shall include complete civil and steel structural works as per plans, drawings & technical specifications for the pipe support foundations.

5.1 SCOPE OF SUPPLY

Contractor shall procure & supply to site all the materials including cement, reinforcing steel, steel sections/plates, pipes, shuttering materials, chequered plate, mesh, bolts and other accessories, other masonry materials, bitumen/asphalt, admixtures & bonding agents, sealants, pavior block, sand, bricks, stones, waterproofing roof materials, boulder, Welding set etc., and any other construction material/ item required to complete the civil & structural works. All costs towards testing/inspection of materials/goods shall be borne by the Contractor. No materials/items shall be supplied by the Owner.

5.2 SITE WORK

Complete construction work including supply of labour, construction materials, construction equipment, survey, tools & tackles, dismantling & modification/strengthening, supervision, testing etc. required to complete all the structures, pipe support foundations as specified and required to complete the civil in all respect. Special permits such as 'Hot Permit', "Fire Safety Permit", "permissions for controlled blasting of rock from concerned authorities" etc. to work at terminals shall be contractor's responsibility.

5.3 PIPE SUPPORT FOUNDATIONS

Pipe supports shall be provided as per mechanical layout drawings for piping. The pipe support may lie within the process area or at any other location. The pipe support foundations shall be designed to take care of the loads and it's fixing details as per standard drawings. Pipe support in process area shall be integral part of pavement. Isolated pipe supports shall however be provided outside the process area.

5.4 CONSTRUCTION MATERIALS

CONCRETE

Cement concrete used shall comply with provisions of IS: 456-2000. All RCC works shall be in design mix concrete of grade M 25 with 20mm and down size aggregate & PCC Works shall be in nominal mix.

CEMENT

Approved quality of Ordinary Portland Cement of Grade 43 / Grade 53 shall be used for reinforced concrete works; and Portland Pozzalano Cement may be used for non RCC works such as brick masonry and plaster etc. For all underground structure, Sulphate Resistant Cement (SRC) shall be used in accordance with Indian Standards based on detail soil investigation report.

Technical specification for Fire Fighting system works	Doc No.	Rev	 Page 38 of 86
	GAIL-STD-FF-DOC-TS-001	0	
	Page 13 of 15		

AGGREGATE

Aggregates shall be from approved sources and shall comply with IS 383. Fine and coarse aggregates shall be considered separate ingredients. Both shall meet the grading requirements of IS 383. Aggregates shall be clean, hard, durable, chemically inert and impermeable. They shall be free from adherent coatings, laminated particles or admixtures of materials likely to be deleterious to the concrete. Dune and beach sand shall not be used for fine aggregate. The grading for Sand shall conform to IS: 383-1970 and shall be within the limit of Grading Zone-III. The maximum size of particle shall be 4.75mm and shall be graded down.

WATER

Water used for concrete shall be clean and free from oil, acid, alkali, organic matter or other harmful matter in such quantities as would affect the concrete in the plastic or hardened state. Potable water shall generally be considered satisfactory for mixing of concrete. Tests on water samples shall be carried out in accordance with IS: 3025 and they shall fulfill the guidelines and requirements of IS: 456.

BRICKS

Bricks shall be locally available bricks minimum of class designation 7.5 conforming to IS: 1077.

REINFORCEMENT STEEL

Reinforcement bars for RCC will be High Yield Strength Deformed/TMT steel bars for Grade Fe 415 / Fe 500 D conforming to IS: 1786-2008 and MS bars of Grade I conforming to IS: 432 (Part-I).The maximum spacing of bars shall be as per IS: 456.

STRUCTURAL STEEL

Structural steel is to be used for general structural purposes shall be of grade Fe 415 MPa conforming to IS: 2062. The minimum yield strength of steel shall be 410 MPa. The minimum yield strength for steel structure shall be as follows:

- Thickness <20 mm 250 MPa
- Thickness 20-40 mm 240 MPa
- Thickness >40 mm 230 MPa

Equipment supports, Access / Operating platforms and crossover shall be fabricated from the structural steel as per requirement. All structural supports, operating platforms & cross over shall be protected with suitable paintings as specified.

Minimum thickness for various structural components shall be as follows:

- Stiffeners: 8mm
- Base Plates: 10mm
- Chequered Plate: 6mm
- Grating: 3mm

ANCHOR BOLTS

Materials for anchor bolts shall be of mild steel conforming to IS: 226 and IS:432 grade-I. Materials such as MS bars, washers, nuts, pipe sleeves and plates etc. shall conform to IS : 1363 & IS : 1364 of 1992.

GROUT

Approved quality Non Shrink (Premix Type), free flow grout shall be provided for all anchor bolts, sleeves, pockets, & spaces under column bases, shoe plate etc. with a crushing strength of 28 days minimum 40 MPa.

WELDING

Welding shall conform to IS 814 -1963. Structural Steel shapes shall conform to IS: 808 (Hot Rolled Steel Beam, Column, Channel & angle Section).



GAIL INDIA LIMITED

**CONSTRUCTION & LAYING OF FIRE WATER NETWORK INSIDE THE
GAIL TERMINAL AT SUVELI**

DATA SHEET FOR VALVE

GAIL-STD-PI-DOC-DS-001

0	25.08.2020	Issued as Standard Specification	SR	TR	SB	
Rev	Date	Purpose	Prepared By	Checked By	Approved By	

Data sheet of Isolation Valve/Gate Valve

Standard
Size Range

API 600
4" to 20"

Piping Class : A1A,A3A, Rating 150 Class
Ends : FLGD to B16.5 RF SERR Fin.

S.No.	Valve Description	Construction	Material
1	Body	Cast	ASTM A216 GR. WCB
2	Bonnet	Bolted	ASTM A216 GR. WCB
3	Stem	Rising	13% CR steel (no Casting)
4	Wedge disk	Flexible	13% CR facing
5	Body seat ring	Renewable	13% CR steel
6	Stem Packing	Renewable with valve open on stream	Graphite asbestos with sacrificial wire Reinforcement.
7	Hand wheel		Malleable iron /cast ST/ FAB. ST/ Duct. Iron
8	Bonnet bolts		ASTM A 193 GR B7 (GALV)
9	Bonnet nuts		ASTM 194 GR 2H (GALV)
10	Bonnet gasket		Spiral wound SS 304 with CA filler
11	Back seat & shoulder		13% CR steel
12	Hydrostatic test pressure		Body :450 PSI Seat : 315 PSI
13	Test pressure with air		80 PSI
14	Valve will be supplied with companion standard flanges & fasteners at both the end.		

NOTES:

1. Bidder shall clearly write all / any deviation against each part/material of valve in the space provided for wherever bidder agrees with GAIL's spec bidder shall indicate "Agreed".
2. No cutting / overwriting by bidder on GAIL's spec is allowed.
3. Testing as per API 596.
4. Pre dispatch inspection at vendors works by GAIL/LEPL Representative.
5. Guarantee of the material for a period of one year against any manufacturing defect shall be offered.



GAIL INDIA LIMITED

**CONSTRUCTION & LAYING OF FIRE WATER NETWORK INSIDE THE
GAIL TERMINAL AT SUVELI**

**DATA SHEET FOR DOUBLE HEADED
HYDRANT SYSTEM**

GAIL-STD-PI-DOC-DS-002

0	25.08.2020	Issued as Standard Specification	SR	TR	SB	
Rev	Date	Purpose	Prepared By	Checked By	Approved By	

Data sheet of Double headed Hydrant system

S.No.	Description	Construction
1	Type	Instantaneous
2	Size	63mm
3	Inlets	Flanged as per IS/ANSI Inlet hole 100mm.
	Material of Construction	
4	Body	GM/SS 304/SS316
	Hydrostatic Test	
5	Body	21 Kg/cm ²
6	Seat	14 Kg/cm ²
7	Hand wheel	150mm Cast iron
8	Paint	Fire red as per IS:5 Shade 536
9	Marking	ISI(Bureau of Indian standard)
10	Drawing No.	

NOTES:

1. Bidder shall clearly write all / any deviation against each part/material of Double headed hydrant system in the space provided for wherever bidder agrees with GAIL's spec bidder shall indicate "Agreed".
2. No cutting / overwriting by bidder on GAIL's spec is allowed.
3. Pre dispatch inspection at vendors works by GAIL/LEPL Representative.
4. Guarantee of the material for a period of one year against any manufacturing defect shall be offered.



GAIL INDIA LIMITED

**CONSTRUCTION & LAYING OF FIRE WATER NETWORK INSIDE THE
GAIL TERMINAL AT SUVELI**

DATA SHEET FOR WATER MONITOR

GAIL-STD-PI-DOC-DS-003

0	25.08.2020	Issued as Standard Specification	SR	TR	SB	
Rev	Date	Purpose	Prepared By	Checked By	Approved By	

Data sheet of Water Monitor

S.No.	Description	Construction
1	Type	Type-1
2	Size	Inlet 2.5"/3"/4"
3	Design & Dimensions	IS : 8442
	Material of Construction	
4	Water Barrel	C-Class
5	Swivel joint	GM
6	Base Flange	MS
7	Lock	Brass
8	Nozzle	Aluminium/SS/Cu Alloy
	Hydrostatic Test	
9	Body	300 psi
	End Connection	
10	Inlet	Flanged
11	Outlet	38mm/50mm/63mm
12	Marking	

NOTES:

1. Bidder shall clearly write all / any deviation against each part/material of Water Monitor in the space provided for wherever bidder agrees with GAIL's spec bidder shall indicate "Agreed".
2. No cutting / overwriting by bidder on GAIL's spec is allowed.
3. Pre dispatch inspection at vendors works by GAIL/LEPL Representative.
4. Guarantee of the material for a period of one year against any manufacturing defect shall be offered.



GAIL INDIA LIMITED

**CONSTRUCTION & LAYING OF FIRE WATER NETWORK INSIDE THE
GAIL TERMINAL AT SUVELI**

DATA SHEET FOR FIRE HOSE CABINET & ACCESSORIES

GAIL-STD-PI-DOC-DS-004

Rev	Date	Purpose	Prepared By	Checked By	Approved By
0	25.08.2020	Issued as Standard Specification	SR	TR	SB



Data sheet for Fire Hose Cabinet & Accessories

S.No.	Description	Construction
A	FIRE HOSE CABINET	
1	Type	Double door
2	Size	750mm x 650mm x 250mm
	Material of Construction	
3	Body	GI/FRP
4	Glass	3mm/4mm
B	HOSE REEL	
1	Type	Wall mounted/swing type
2	Size Hanging	30m/60m
	Material of Construction	
3	Body	MS
4	Swivel	MS/Brass
5	Nozzle	Brass/SS/Plastic
C	HOSE PIPE WITH COUPLING	
1	Type Hose	CP/Type-A/Type-B
2	Size	63mm
3	Length	15m/30m
	Material of Construction	
4	Hydrostatic Test	21 Kg/cm ²
5	Marking	ISI/UL/Kite mark
D	FIRE HOSE DELIVERY COUPLING	
1	Type	Instantaneous
2	Size	30mm/50mm/63mm/70mm
3	Design & Dimensions	BS 336
	Material of Construction	
4	Body	Gun Metal
5	Hydrostatic Test	21 Kg/cm ²
6	Drawing No.	

NOTES:

1. Bidder shall clearly write all / any deviation against each part/material of Water Monitor in the space provided for wherever bidder agrees with GAIL's spec bidder shall indicate "Agreed".
2. No cutting / overwriting by bidder on GAIL's spec is allowed.
3. Pre dispatch inspection at vendors works by GAIL/LEPL Representative.
4. Guarantee of the material for a period of one year against any manufacturing defect shall be offered.

FORMS & FORMATS

Area Permitted	
Yellow	Red
Offshore	



CONTRACT EMPLOYEE ENTRY PERMIT FORM (PERM)
(FILL IN BLOCK LETTERS)

Form -A

NAME OF THE CONTRACTOR: _____ W/O NO _____ GATE PASS NO. _____ VALID FROM _____ TO _____ DATE: _____

Name : _____ Son of _____ Surname _____ Age _____ Years DOB _____ / _____ / _____ Blood Group _____ Sex : Male / Female Married / Unmarried _____ Identification marks _____ Religion _____ QUALIFICATION _____ POLICE CLEARANCE CERTIFICATE ATTACHED: _____ Designation _____ SKILLED <input type="checkbox"/> SEMISKILLED <input type="checkbox"/> UNSKILLED <input type="checkbox"/> Department _____	Present Address House No. _____ Street _____ Town / Village _____ P.O. _____ Mo: _____ Telegraph Office _____ Dist. _____ State _____	Permanent Address House No. _____ Street _____ Town / Village _____ P.O. _____ Mo: _____ Telegraph Office _____ Dist. _____ State _____	Specimen Signature 1 _____ 2 _____ Thumb Impression Left: _____ Right: _____
Photograph _____ Contractor's Full Address _____ Supervisor's full Add. _____ Mob. No. _____	Contractor's Name of Immediate Relative & Address _____ Mob. No. _____	Name of Immediate Relative & Address _____ Mob. No. _____	Nature / Place of Work CIL - SECURITY & SEAL

I request you to kindly issue the Gate Pass to the above mentioned person. I hereby certify that the data given above is true to the best of my knowledge & discrepancy if any observed later, will be sole responsibility. I also undertake for entire Conduct & Behavior of above Person In & around the company Premises.
Contractors Authorized person Signature & Seal

CIL Approval:-

Sign: _____ Name: _____ Designation: _____	Sign: _____ Name: _____ Designation: _____ Validity: _____	Sign: _____ Name: _____ Designation: _____	Sign: _____ Name: _____ Designation: _____
User Department		Medical Department	
HR/ Admin		HSE	
Security Manager		Security Manager	

HEALTH DECLARATION FORM

NAME: _____ AGE: _____ CONTACT NO: _____
 COMPANY: _____ EMP.ID NO.: _____ DESIGNATION: _____
 DATE & TIME: _____ Present Address: _____ EMERGENCY CONTACT NO: _____

Travel History of Employee:

Travel History of family members/ roommate:

Are you residing in the Containment area (Cluster Zone):

Any relatives/ friends visited to your home from Containment area (Cluster Zone):

MEDICAL HISTORY:

1. DO YOU HAVE ANY KNOWN ALLERGIES? YES / NO
2. ANY BAD REACTION / SIDE EFFECT FROM ANY MEDICATION? YES / NO
3. HAVE YOU PURCHASED RECENTLY OVER THE COUNTER MEDICATION FOR FEVER OR SORE THROAT? YES / NO
4. ARE YOU PRESENTLY SUFFERING FROM ANY OF THESE SYMPTOMS AS:
 - A) FEVER
 - B) SNEEZING
 - C) COLD
 - D) COUGH & BREATHLESSNESS
 - E) VOMITTING
 - F) DIARRHOEA
5. HISTORY OF CONTACT WITH ANYONE WITH THE ABOVE SYMPTOMS OR A SUSPECTED CASE OF CORONAVIRUS IN THE PAST 1 TO 2 WEEKS? YES / NO
6. DO YOU HAVE ANY RECENT OR PAST HEALTH PROBLEM, FOR WHICH YOU HAVE BEEN PRESCRIBED MEDICATION? (NEED TO TAKE SUFFICIENT SUPPLY & STORE THEM APPROPRIATELY) YES / NO
7. HAVE YOU TRAVELLED TO CLUSTER AREA OR ANY OF THE AFFECTED AREA (AS DECLARED BY GOVERNMENT) OR OTHER STATES OR OTHER PLACES WHERE COVID-19 VIRUS PREVALENT. YES / NO
8. ANY RELATIVES VISITED FROM CONTAINMENT ZONE (CLUSTER AREA) TO YOUR HOME?

9. VITAL SIGNS: -

TEMP:

PULSE:

BLOOD PRESSURE:

FIT / UNFIT / REQUIRE ISOLATION / REFERRAL:

ALL INFORMATION GIVEN REGARDING SYMPTOMS / TRAVEL HISTORY ARE CORRECT TO MY KNOWLEDGE

SITE DR. SIGNATURE:

EMP.SIGNATURE:

(NAME IN CAPITAL LETTERS & REG. NO.)

(NAME IN CAPITAL LETTERS) NOTE: THIS

INFORMATION WILL BE HELD IN CONFIDENCE IN ACCORDANCE WITH THE DATA PROTECTION ACT.

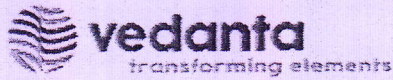

Self-Declaration Medical Fitness Form:

I, _____ (Full name of Applicant),
Date of Birth: _____, Blood Group: _____,
from (Company Name) _____,
Address: _____ Phone: _____

Declare that I am medically fit to work in M/s Vedanta/ Cairn India Limited – Suvali, offshore and onshore facility. To the best of my knowledge and belief, there is no other medical condition or disability likely to prevent me from performing my duties effectively without creating an unacceptable risk to the safety of myself, or other members of the crew.

Signed by the Applicant:

Date:

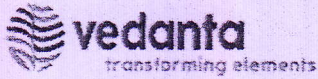

Drug & Alcohol Declaration Form

I _____, Employee No. _____, from M/s _____, declare that I am aware of CIL's Drug & Alcohol Policy. I am not carrying Drug / Alcohol / smoking materials like (Cigarettes & Match box) within the CIL's premises and I have not consumed of Drug/ Alcohol. I give my full consent without any objection to Security personnel / Paramedic personnel to carry out Drug / Alcohol test, if required.

Signed: _____

Date: _____



HAZIRA POLICE STATION

LABOUR DETAIL FORM

ALL DETAIL ARE MANDATORY, INCOMPLETE FORM NOT ACCECTABLE

CONTRATOR/OWNER WILL BE RESPONSIBLE IF COMPLETED IS NOT GIVEN

1	FULL NAME OF LABOUR CONTRACTOR SUPLIER ADDRESS WITH NO	:	
2	NAME OF LABOUR AND AGE	:	
3	PRESENT ADDRESS OF LABOUR & TELEPHONE NO	:	
4	PERMANENT ADDRESS OF LABOUR	:	
5	WORKING PLACE/NAME OF THE COMPANY	:	
8	LOCAL POLICE STATION (AT NATIVE PLACE) NAME AND TELEPHONE NO.	:	
7	NAME ADDRESS CONTACT NO. OF LOCAL LEADER/SARPLUNCH (NATIVE PLACE)	:	
8	CRIMINAL DETAILS OF THE LABOUR (IF ANY)	:	
9	DATE OF JOINING WITH THE CONTRACTOR	:	
10	ID PROOF OF LABOUR WITH PHOTOGRAPH	:	
11	SURAT CITY ARRIVAL & DEPARTURE DATE (AS & WHEN)	:	
12	IF RELATIVE ARE LIVING SURAT CITY PROVIDE THEIR NAME ADDRESS AND CONTACT NO.	:	
13	NAME ADDRESS AND CONTACT NO. OF BROTHER AND SISTER OF LABOUR	:	
14	NAME ADDRESS AND CONTACT NO. OF LABOUR UNCLES (CHACHA/MAMA)	:	
15	PRESENT ADDRESS AND IF ANY PERSON IF FORM HIS/HER VILLAGE NAME	:	
	(SIGNATURE WITH THUMB IMPRESSION OF LABOUR / SERVANT	:	
	SIGNATURE OF OWNER/SUPLIER/CONTRACTOR FULL NAME	:	

Police Clearance Certificate Declaration undertaking by Employer

"It is hereby certified that Name Mr. /Ms. /Mrs. _____ Son/Daughter Of
_____ Employee ID/No. _____, Resident of
_____ is working with this organization since / / as (designation/profile
name).

Mr. /Ms ./ Mrs. _____ bears good moral character to the best of my
knowledge; is not involved in any criminal activity and no personal legal cases are pending
against him/her.

His / Her Background Verification has been carried out which is found satisfactory. "

Signature (with seal)

Name _____

Date _____

Place _____

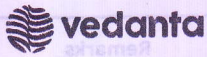

HOT WORK PERMIT

(Valid for One Day only)

001209

CB/HW
PERMIT NO.



- Attachments:**
- | | | | |
|---|---|--|---|
| <input type="checkbox"/> Confined Space Entry | <input type="checkbox"/> HV Isolation | <input type="checkbox"/> Temp. Override | <input type="checkbox"/> Critical Lift Plan |
| <input type="checkbox"/> Well Hand Over Form | <input type="checkbox"/> Electrical Isolation | <input type="checkbox"/> Temp. Power | <input type="checkbox"/> Scaffold Insp |
| <input type="checkbox"/> Hide / Habitat | <input type="checkbox"/> Excavation/Penetration | <input type="checkbox"/> Mech. Isolation | <input type="checkbox"/> Radiography |

Valid from : Hrs. tohrs. Date :/...../..... No of Person:

1 Applicant Name: Signature : Section/Department:

Location of Work : Equipment work on :

Tools/Equipment : Tag No.

Ref. : Work Permit No. (Master Permit) :

Description of Work :

JHA Required ? Yes/NO Work Instruction Required ? Yes/NO

Safety and Loss Prevention Requirements (Tick all relevant item in box)

A) Hazards

- | | | | | |
|--|--|--|--|---|
| <input type="checkbox"/> Slip, Trip | <input type="checkbox"/> Awkward Access | <input type="checkbox"/> Toxic Gas Fumes | <input type="checkbox"/> Steam | <input type="checkbox"/> Work at Height |
| <input type="checkbox"/> Inadequate lighting | <input type="checkbox"/> Unguarded Opening | <input type="checkbox"/> Hazardous Substance | <input type="checkbox"/> Noise | |
| <input type="checkbox"/> Dropped Object | <input type="checkbox"/> Flammable Materials | <input type="checkbox"/> SIMOPS | <input type="checkbox"/> Vibration | |
| <input type="checkbox"/> Electric Shock | <input type="checkbox"/> Hot Surface | <input type="checkbox"/> Overboard Work | <input type="checkbox"/> High Pressure | |

Other Hazard :

B) Controls

- | | | | | |
|--|--|--|---|--|
| <input type="checkbox"/> Barricade | <input type="checkbox"/> Additional Lighting | <input type="checkbox"/> Equipment Earthing | <input type="checkbox"/> Fire Extinguisher | <input type="checkbox"/> Isolate |
| <input type="checkbox"/> Sign & Barriers | <input type="checkbox"/> Purged | <input type="checkbox"/> Fire/Safety Watcher | <input type="checkbox"/> Manual Handling | <input type="checkbox"/> Flammable Removed |
| <input type="checkbox"/> MSDS Precaution | <input type="checkbox"/> Safe Access/Egress | <input type="checkbox"/> De-Pressurized | <input type="checkbox"/> Vented | |
| <input type="checkbox"/> Drained | <input type="checkbox"/> Insulated Tools | <input type="checkbox"/> Secure Loose Object | <input type="checkbox"/> De-Energies | |
| <input type="checkbox"/> Fire Tender Standby | <input type="checkbox"/> Blind | <input type="checkbox"/> Drain Flush/Covered | <input type="checkbox"/> Continuous/Intermittent Gas Monitoring | |

C) PPE Required- Safety Shoes, Helmets, Coverall and Goggles are mandatory

- | | | | |
|---|--|--------------------------------------|------------------------------------|
| <input type="checkbox"/> Gloves PVC/Leather/Heat Resistant/Cotton | <input type="checkbox"/> Body Protection | <input type="checkbox"/> Dust Mask | <input type="checkbox"/> Work Vest |
| <input type="checkbox"/> Ear Protection | <input type="checkbox"/> Full Body Harness | <input type="checkbox"/> Face Shield | <input type="checkbox"/> Other: |

D) Additional Precaution :

3 Any other Permit in this area ? Yes/NO Permit No.

4 This work is authorized to proceed provide the above mentioned precaution are adhere to.

5 Precautions prescribed above are checked and adhered to and work can now proceed provided the site is certified safe to work.

Name of the production In-charge : Signature :

Initial Gas Test Results

6 A new gas test must be carried out at every validation of this permit. The test result are to be recoded below and carry on to the reverse of this permit.

Time	LEL (%)	O2 (%)	Other	Name of the Authorized Gas Tester	Signature

7 I have personally checked/actioned all the above requirements and certify that the work site is safe to work.

Name of Area Engineer : Sign : Date : Time :

8 I understand the precautions that must be taken and I abide by them. It is my responsibility to maintain a clean and orderly work site.

Name of Permit Holder : Sign : Date : Time :

Name of Welder : Sign : Date : Time :

Permit Sign Off

I declare that all persons have been withdrawn and that all tools, Plant and equipment used have been removed bad the site is rendered clean & safe.

Complete Incomplete Cancelled

9 Permit Holder Sign. Area Engineer Sign Permit Applicant Sign

Issuing Authority : I declare that Work is complete and permit is now closed.

Complete Incomplete Cancelled

Name : Sign : Date : Time :

Distribution : Pink (Red Border) Copy - Work Site

Light Blue Copy - Control Room



HIDE CHECKLIST

1012

Applicant's Name : Initiator Name : Section / Dept. :

INSTRUCTIONS :

- 1) Select items applicable by placing an 'X' in the YES or NO box
- 2) Submit for approval to the Permit Authority with the Work Permit
- 3) This Checklist is valid for the duration of the relevant Work Permit
- 4) The Permit Holder shall initiate all items specified PRIOR to Permit issue.

NOTE : Attach copies of this Checklist to copies of the relevant Work Permit.

CAUTION : ITEMS TO BE ACTIONED PRIOR TO OMMENCEMENT OF WORK	YES	NO
Initial Gas Monitor outside hide and at air intake		
Fire hose run and pressurised		
Portable monitors set up if insufficient deluge coverage		
Fire extinguishers inside and outside (Dry Chemical)		
Fire blankets around weld zone		
Welding machine sited inside hide / in safe location		
Step down transformer sited inside hide or at safe location		
Welding cables continuous run (no joins)		
Container for welding stubs in hide		
Work tools and equipment at site, assembled and checked		
Low voltage lighting only		
Welding cable earth clamp attached to work-piece inside		
Escape routes identified		
Hide well secured at work site		
Checke for clash with other work in module / vicinity		
Sewers and vents covered		
Other (Specify) :		

NOTE : ITEMS TO BE STRICTLY ADHERED TO FOR THE DURATION OF WORK

- | | |
|---|---|
| <ul style="list-style-type: none"> ● Stop work in cases of changed conditions or other hazards ● Spotter outside with radio and in radio contact with Control Room ● Contain all sparks / weld flashes within hide | <ul style="list-style-type: none"> ● Notify Control Room before commencement of Hot Work/Welding ● Notify Control Room on completion of Hot Work / Welding ● Light up and extinguish gas torches inside, remove when not in use. |
|---|---|

Sign. : (HSE Engr.) (Area Engr.) (PIC)

Permit Holder Name :

Section/Dept.:

INSTRUCTIONS :

- 1) Select items applicable by placing an 'X' in the YES or NO or NA box
 - 2) This checklist is valid for the duration of the relevant work permit
 - 3) The permit Holder shall initiate all items specified PRIOR to permit issue.
- NOTE : Attach copies of this checklist to copies of the relevant work permit.

CAUTION : ITEMS TO BE ACTIONED PRIOR TO OMMENCEMENT OF WORK	YES	NO	NA
Initial Gas Monitor outside hide			
Fire hose run and pressurized			
Portable monitors set up for gas monitoring			
Fire extinguishers kept nearby (DCP)			
Fire blankets around weld zone well secured			
Falammable material removed around 10 m from hot work area			
Work tools and equipment at site assembled and checked			
Welding cable earth clamp attached to work-piece inside			
Escape routes identified			
Location of MCP identified in case of emergency use			
Sewers, drains, opening and vents covered properly			
Other (Specify) :			

NOTE : ITEMS TO BE STRICTLY ADHERED TO FOR THE DURATION OF WORK

- Stop work in cases of changed conditions or other hazards
- Gas cylinder to be secured with trolley before use
- Contain all sparks/weld flashes within hide
- Notify Control Room before commencement of Hot Work/Welding
- Notify Control Room on completion of Hot Work / Welding
- Light up and extinguish gas torches inside, remove when not in use.

Permit Holder Name:

Signature:

Area Engineer Name:

Signature:

Fire Watcher Name:

Signature:



SPARK POTENTIAL PERMIT (Valid for Seven Days only)

001493

CB/SP
PERMIT NO.



- Attachments:**
- | | | | |
|---|---|---|---|
| <input type="checkbox"/> Confined Space Entry | <input type="checkbox"/> HV Isolation | <input type="checkbox"/> Temp. Override | <input type="checkbox"/> Critical Lift Plan |
| <input type="checkbox"/> Well Hand Over Form | <input type="checkbox"/> Electrical Isolation | <input type="checkbox"/> Temp. Power | <input type="checkbox"/> Scaffold Insp |
| <input type="checkbox"/> Excavation/Penetration | <input type="checkbox"/> Mech. Isolation | <input type="checkbox"/> Solorun | <input type="checkbox"/> Radiography |

Valid from : Hrs toHrs Date :/...../..... No of Person:

Applicant Name: Signature : Section/Department:

Location of Work : Equipment to be work on :

Tools/Equipment : Tag No.

Ref. : Work Permit No. (Master Permit) :

Description of Work :

JHA Required ? Yes/NO Work Instruction Required ? Yes/NO

Safety and Loss Prevention Requirements (Tick all relevant item in box)

A) Hazards

- | | | | | |
|--|--|---|--|--|
| <input type="checkbox"/> Slip, Trip | <input type="checkbox"/> Awkward Access | <input type="checkbox"/> Toxic Gas Fumes | <input type="checkbox"/> Hot Surface | <input type="checkbox"/> Work at Height |
| <input type="checkbox"/> Inadequate lighting | <input type="checkbox"/> Unguarded Opening | <input type="checkbox"/> Hazardous Substance | <input type="checkbox"/> Noise | <input type="checkbox"/> SIMOPS |
| <input type="checkbox"/> Dropped Object | <input type="checkbox"/> Flammable Materials | <input type="checkbox"/> Hydrocarbon presence | <input type="checkbox"/> Vibration | <input type="checkbox"/> Pressurised Hose Pipe |
| <input type="checkbox"/> Overboard Work | <input type="checkbox"/> Radioactive Source | <input type="checkbox"/> Static Electricity | <input type="checkbox"/> High Pressure | <input type="checkbox"/> Machine Guard removal |

Other Hazard :

B) Control in Place :

- | | | | | |
|--|--|--|--|---|
| <input type="checkbox"/> Initial Gas testing | <input type="checkbox"/> Additional Lighting | <input type="checkbox"/> Equipment Earthing | <input type="checkbox"/> Fire Extinguisher | <input type="checkbox"/> Intrinsically Safe Equip |
| <input type="checkbox"/> Sign & Barriers | <input type="checkbox"/> Purged | <input type="checkbox"/> Fire/Safety Watcher | <input type="checkbox"/> Manual Handling | <input type="checkbox"/> Flammable Removed |
| <input type="checkbox"/> MSDS Precaution | <input type="checkbox"/> Safe Access/Egress | <input type="checkbox"/> De-Pressurized | <input type="checkbox"/> Vented | <input type="checkbox"/> Hose Whip check |
| <input type="checkbox"/> Drained | <input type="checkbox"/> Insulated Tools | <input type="checkbox"/> Secure Loose Object | <input type="checkbox"/> De-Energies | <input type="checkbox"/> Blind |
| <input type="checkbox"/> Fire Tender Standby | <input type="checkbox"/> Cover Drain | <input type="checkbox"/> Machine guard refixed after job | | |

C) PPE Required- Safety Shoes, Helmets,Coverall and Goggles are mandatory

- | | | | |
|---|--|--|------------------------------------|
| <input type="checkbox"/> Gloves PVC/Heat Resistant/Cotton | <input type="checkbox"/> Body Protection | <input type="checkbox"/> Dust Mask | <input type="checkbox"/> Work Vest |
| <input type="checkbox"/> Ear Plug | <input type="checkbox"/> Full Body Harness | <input type="checkbox"/> Face Protection | <input type="checkbox"/> Other: |

D) Additional Precaution :

3 Any other Permit in this area ? Yes/NO Permit No.

4 This work is authorized to proceed provided the above mentioned precaution are adhere to. Signature of Installation/Production Manager

5 Precautions prescribed above are checked and adhered to and work can now proceed provided the site is certified safe to work.

Name of the production In-charge : Signature :

Initial Gas Test Results

A new gas test must be carried out at every validation of this permit. The test result are to be recoded below and carry on to the reverse of this permit.

Time	LEL (%)	O2 (%)	Other	Name of the Authorized Gas Tester	Signature

7 I have personally checked/actioned all the above requirements and certify that the work site is safe to work.

Name of Area Engineer : Sign : Date : Time :

8 I understand the precautions that must be taken and I abide by them. It is my responsibility to maintain a clean and orderly work site.

Name of Permit Holder : Sign : Date : Time :

Permit Sign Off

I declare that all persons have been withdrawn and that all tools, Plantand equipment used have been removed and the site is rendered clean & safe.

Complete Incomplete Cancelled

.....
Permit Holder Sign. Area Engineer Sign Permit Applicant Sign

Issuing Authority : I declare that Work is complete and permit is now closed..

Complete Incomplete Cancelled

Name : Sign : Date : Time :

Distribution : Yellow (Orange Border) Copy- Work Site

Light Blue Copy - Control Room

Vedanta Fatal Risk Control Safety Standard Check List - Mobile Crane & Lifting

Date		Time	
	Mobile Crane / Lifting Activity to be carried out		
	Location/ Job Site		
	Crane Registration Number		

Sr. No.	Audit checkpoint(s)	Status (Yes, No, NA)	Observations	Remarks
1	Is crane inspected by a 3rd party and Vedanta rep before mobilization and periodically there after?			Contract or hire cranes shall be inspected by a 3rd party and Vedanta rep at contractor's location before mobilization with a documented and recorded checklist
2	Is authorized permit with Lift Plan is available? Is the Lift categorized as Routine or Critical Lift?			A Critical Lift is greater than 75% of the maximum rated load in the specific lifting configuration; multiple crane lifts; lifts over operating facilities where this may endanger personnel; lifts over power lines; and lifts involving personnel cages
3	If critical lift, Lift plan is available and approved by competent person?			Any person designing or approving a lifting plan must be trained and certified as competent through a Vedanta approved approach or a National certification system
4	Are Crane Operator, riggers and signal man Trained and Certified / Authorised as competent? Check valid documents.			The crane operator, riggers and signal man must be trained and annually certified by authorized agencies approved by Vedanta, ideally the crane OEM.
5	Is job specific risk assessment carried out for critical Lifts?			Ensure all relevant risks are captured. The operator's experience, skill and knowledge of the particular crane should be given due consideration.
6	Is pre-operational safety check carried out by the operator?			Operators must undertake a pre-operational safety check for each shift that must be based

				on a risk assessment for the equipment.
7	Do the rigging hardware have valid certificates from a competent person?			
8	Are all lifting gear / equipment available with valid colour code?			Verify prevailing colour code for Lifting Equipment.
9	Check if the lifted load is within 90% of the maximum rated load.			
10	Check of all safety devices or overload limit switches are functional and are not in override or cut out position.			
11	Check for working area free from any unforeseen hazard e.g. excavation, scaffolding, occupied building, process equipment etc.			
12	Is load well secured and properly balanced in the sling or lifting device?			
13	Is adequate means of communication with the crane operator available?			E.g. Clear visibility for Hand Signal or two way radio communication.
14	Was pre-lift meeting with all members of the lifting team conducted?			
15	Are tag lines available for both the side of loads which require steadying or guidance while load is suspended?			Ensure hands off from load during handling of load.

Name of Cairn Supervisor Signature
--



गैल (इंडिया) लिमिटेड
(भारत सरकार का उपक्रम - महारक्षण कंपनी)
GAIL (India) Limited

(A Government of India Undertaking - A Maharatna Company)

हजिरा कम्प्रेसर स्टेशन,
इच्छापुर बागलसा रोड,
पी. ओ. : सी.एच.सी.सी.,
जिला : सुरत - 394 518
HAZIRA COMPRESSOR STATION
ICCHAPURE MAGDALLA ROAD,
P.O. : C.H.S.C.,
Dist. SURAT - 394 518
फोन / PHONE : (0261) 2917304/2905734
फैक्स / FAX : (011) 26186941

Sr. No	Checkpoints	Conditions	Remarks
1	General condition of Crane and cleanliness		
2	Main Boom		
3	Jib Boom / Boom Extn.		
4	Hook Block Condition		
5	Safety Latches		
6	Hoist Rope Condition		
7	Wire Rope Anchoring / Saddle Clamp		
8	Anti-Block Device		
9	Overload, over hoist alarm and cut off		
10	Load Chart Availability		
11	Hydraulic system (no leakages)		
12	Condition Of Hyd. Hoses		
13	Electrical Wiring & Rooting		
14	Drivers Cab & Controls		
15	Clear Vision to Operator(Mirrors/Windows)		
16	Rotating Light		
17	Condition Of Tyres		
18	Check Tyre Pressure		
19	Seat Belt		
20	Horn and Reverse alarm		
21	Rotating Light		
22	First aid kit		
23	Fire extinguisher		
24	Check all the movements		
25	Functioning of SLI		
Operator Sign			
GAIL HSE Supervisor Sign			



गैल (इंडिया) लिमिटेड
(गैल गैसफोरम का अग्रक्रम - भारतीय कंपनी)
GAIL (India) Limited
(A Government of India Undertaking - A Maharatna Company)

हजिरा कम्प्रेसर स्टेशन,
इच्छापुर मगदल्ला रोड,
पो. को. : ओ.एन.जी.सी.,
जिला : सुरत - 394 518
HAZIRA COMPRESSOR STATION
ICCHAPURE MAGDALLA ROAD,
P.O. : O.N.G.C.,
Dist. SURAT - 394 518
फोन / PHONE : (0261) 2917304/2908734
फैक्स / FAX : (011) 26185941

Hydra Pre-use Inspection checklist

Date of inspection: _____

Date Of Purchasing		Insurance Validity	
Vehicle Model		Road Tax Validity	
Registration Number		Fitness Validity.	
Contractor Name		Vehicle TPI	
Odometer Reading		Operator TPI	
Inspection Date		PUC Validity	
Location		Driving License no.	



GAIL INDIA LIMITED

**LIST OF APPROVED PARTIES
FOR
BOUGHT OUT ITEMS**

Rev	Date	Purpose	Prepared By	Checked By	Approved By
0	29.08.2019	Issued for Bid	RKS	UN	SB



TABLE OF CONTENTS

1. MAINLINE & MECHANICAL.....3
2. CIVIL & STRUCTURE.....17
3. INSTRUMENTATION.....34
4. SHOP & FIELD PAINTING.....42

LIST OF APPROVED PARTIES FOR BOUGHT OUT ITEMS	Doc No.	Rev	
	GAIL-ENG-GN-DOC-VL-001	0	
Page 2 of 22			

LIST OF SUPPLIERS OF MAJOR BOUGHT-OUT ITEMS**1. (MECHANICAL & FIRE FIGHTING EQUIPMENT)****A). MAINLINE & MECHANICAL****i) Pipes (1239/3589)**

1. TISCO, Calcutta
2. Jindal Pipes, New Delhi
3. Ajanta Tubes, New Delhi
4. Gujrat Steel Tubes
5. Khandelwal

ii) Valve**a) Globe Valves**

- 1) M/S BDK (New Delhi)
- 2) M/S Datre Corpn (Calcutta)
- 3) M/S KSB Pumps (New Delhi)
- 4) M/S L&T (New Delhi)
- 5) M/S Neco Schuber & Salzer Ltd. (New Delhi)
- 6) M/S Niton Valve (Mumbai)
- 7) M/S Ornate Valves (Mumbai)
- 8) M/S Panchavati Valves (Mumbai)
- 9) AV Valves Ltd.
- 10) BHEL (Trichy), India
- 11) Econo Valves Pvt Ltd, India
- 12) Fouress Engg (I) Ltd (Aurangabad)
- 13) Guru Industrial Valves Pvt Ltd
- 14) Leader Valves Ltd, India
- 15) NSSL Ltd. (Neco Schubert & SalzerLtd)
- 16) Oswal Industries Ltd, India
- 17) Petrochemical Engineering Enterprises, India
- 18) Sakhi Engineers Pvt Ltd
- 19) Shalimar Valves Pvt Ltd
- 20) Steel Strong Valves India Pvt Ltd, India
- 21) Petro Valves Pvt. Limited, Ahmedabad

b) Check Valves

1. M/s Advance Valves Pvt. Ltd., Noida

LIST OF APPROVED PARTIES FOR BOUGHT OUT ITEMS	Doc No.	Rev	
	GAIL-ENG-GN-DOC-VL-001	0	
Page 3 of 22			

2. M/s Aksons & Mechanical Enterprises, Mumbai
3. M/s Larsen & Toubro Limited (M/s Audco India Limited, Chennai)
4. M/s AV valves Ltd., Agra
5. M/s BDK engineering India Ltd., Hubli
6. M/s BHEL, OFE&OE Group, New Delhi
7. M/s Datre Coroportion Limited, Calcutta
8. M/s Leader Valves Ltd., Jalandhar
9. M/s Neco schubert & Salzer Ltd., New Delhi
10. M/s Niton Valves Industries (P) Ltd., Mumbai
11. M/s Precision Engg.Co., Mumbai
12. Econo Valves Pvt Ltd, India
13. Fouress Engg (I) Ltd (Aurangabad)
14. KSB Pumps Ltd (Coimbatore), India
15. NSSL Ltd. (Neco Schubert & SalzerLtd)
16. Oswal Industries Ltd, India
17. Panchvati Valves & Flanges Pvt Ltd, India
18. Petrochemical Engineering Enterprises, India
19. Sakhi Engineers Pvt Ltd
20. Shalimar Valves Pvt Ltd
21. Steel Strong Valves India Pvt Ltd, India

c) Plug Valves

1. M/s Breda Energia Sesto Industria Spa, Italy
2. M/s Fisher Sanmar Ltd., Chennai
3. M/s Larsen & Toubro Ltd., New Delhi
4. M/s Nordstrom Valves, USA
5. M/s Serck Audco Valves, UK
6. M/s Sumitomo Corporation India Pvt. Ltd., New Delhi
7. M/s Z Corporation, Korea
8. M/s Hawa Valves (India) Pvt. Ltd., Mumbai
9. M/s Steel Strong Valves India Pvt. Ltd., Navi Mumbai
10. M/s Econo Valves
11. M/s Flow-Serve PTE (Mfr. SERCK), India

d) Ball Valves

1. M/s Hawa Valves (India) Pvt. Ltd, Navi Mumbai
2. M/s Larsen & Toubro, Delhi

LIST OF APPROVED PARTIES FOR BOUGHT OUT ITEMS	Doc No.	Rev	
	GAIL-ENG-GN-DOC-VL-001	0	
Page 4 of 22			

3. M/s Microfinish Valves Pvt. Ltd., Noida
4. M/s Oswal Industries Ltd., Gandhi nagar
5. M/s Virgo Engineers Ltd., Delhi
6. M/s Boteli Valve Group Co. Ltd., China
7. M/s Cameron (Malaysia) SDN BHD, Malaysia
8. M/s Dafram S.P.A., Italy
9. M/s Fangyuan Valve Group Co. Ltd., China
- 10.M/s Franz Schuck GmbH, Germany
- 11.O.M.S. Saleri (Italy)
- 12.Pibi Viesse S.P.A (Italy)
- 13.Nuovo Pignone (Italy)
- 14.Perar S.P.A (Italy)
- 15.Pietro Fiorentini (Italy)
- 16.Cooper Cameron Valv Italy SRL-FRM, Itly
- 17.Petrol Valves SRL
- 18.Tormene Gas Technology S.P.A (VALVITALIA)

iii) Flow Tee

- 1) M/s Coprosider SPA, Italy
- 2) M/s GEA Energy System India Limited, Chennai
- 3) M/s Multitex Filtration
- 4) M/s Pipeline Engineering, UK
- 5) M/s Scomark Engg. Limited (U.K.)
- 6) M/s Skeltonhall Limited, England(U.K.)
- 7) M/s Technospecial SPA, Italy
- 8) M/s Tectubi SPA, Italy
- 9) M/s RMA Germany
- 10) M/s Pipefit Engineers Pvt. Ltd.

iv) Split Tee

- 1) M/s Ipsco, Canda
- 2) M/s TD Willamsons, USA

LIST OF APPROVED PARTIES FOR BOUGHT OUT ITEMS	Doc No.	Rev	
	GAIL-ENG-GN-DOC-VL-001	0	
	Page 5 of 22		

v) Flanges

1. M/s Aditya Forge Ltd., Vadodara
2. M/s Amforge Industries Ltd., Mumbai
3. M/s CD Engineering Co., Ghaziabad
4. M/s Echjay Forgings Pvt. Ltd. (Bombay), Mumbai
5. M/s Echjay Industries Ltd., Rajkot
6. M/s Forge & Forge Pvt. Ltd., Rajkot
7. M/s Golden Iron & Steel Works, New Delhi
8. M/s JK Forgings, New Delhi
9. M/s Metal Forgings Pvt. Ltd., Mumbai
10. M/s Perfect Marketings Pvt. Ltd., New Delhi
11. M/s Sky Forge, Faridabad
12. M/s S&G, Faridabad
13. Chaudhry Hammer Works Ltd, India
14. JAV Forgings (P) Ltd, India
15. Kunj Forgings Pvt Ltd, India
16. MS Fittings
17. R.N. Gupta & Co. Ltd, India
18. R.P. Engineering Pvt Ltd, India
19. Sanghvi Forgings & Engineering Ltd
20. Shri Ganesh Forgings Ltd., India
21. Uma Shankar Khandelwal & Co., India
22. Sawan Engineers, Baroda
23. Stewarts & Lloyds of India Ltd., Kolkata
24. Engineering Services Enterprises
25. Pipefit Engineers Pvt. Ltd.

vi) Fittings

1. M/s Commercial Supplying Agency, Mumbai
2. M/s Dee Development Engineers Ltd.
3. M/s Eby Industries, Mumbai
4. M/s Flash Forge Pvt. Ltd., Vishakhapatnam
5. M/s Gujarat Infra Pipes Pvt. Ltd., Vadodara
6. M/s M.S. Fittings Mfg. Co. Pvt. Ltd., Kolkata
7. M/s Stewarts & Lloyds of India Ltd., Kolkata

LIST OF APPROVED PARTIES FOR BOUGHT OUT ITEMS	Doc No.	Rev	
	GAIL-ENG-GN-DOC-VL-001	0	
Page 6 of 22			

8. M/s Teekay Tubes Pvt. Ltd., Mumbai
9. M/s Pipe Fit, Baroda
10. M/s Sky Forge, Faridabad
11. M/s S&G, Faridabad
12. M/s Sawan Engineers, Baroda
13. Eby Fasteners, India
14. Leader Valves Ltd, India
15. R.N. Gupta & Co. Ltd, India
16. Exten Engg Pvt Ltd
17. Sivananda Pipe & Fittings Ltd

vii) Gaskets

1. IGP Engineers (P) Ltd., Madras
2. Madras Industrial Products, Madras
3. Dikson & Company, Bombay
4. Banco Products (P) Ltd., Vadodara
5. Goodrich Gaskets Pvt Ltd
6. Starflex Sealing India Pvt Ltd, India
7. Teekay Meta Flex Pvt Ltd
8. UNIKLINGER Ltd
9. HEM Engg. Corp.
10. Unique Industrial Packing Pvt. Ltd.

viii) Fasteners

1. Nireka Engg. Co. (P) Ltd., Calcutta
2. Precision Taps & Dies, Bombay
3. AEP Company, Vithal Udyoug Nagar
4. Fix Fit Fasteners, Calcutta
5. Precision Engg. Industries, Baroda
6. Echjay Forgings Pvt. Ltd., Bombay
7. Capital Industries, Bombay
8. Boltmaster India Pvt Ltd, India
9. Deepak Fasteners Limited, India
10. Fasteners & Allied Products Pvt Ltd, India
11. Hardwin Fasteners Pvt Ltd, India

LIST OF APPROVED PARTIES FOR BOUGHT OUT ITEMS	Doc No.	Rev	
	GAIL-ENG-GN-DOC-VL-001	0	
	Page 7 of 22		

12. J.J. Industries, India
13. Multi Fasteners Pvt Ltd, India
14. Nexo Industries, India
15. Pacific Forging & Fasteners Pvt Ltd, India
16. Pioneer Nuts & Bolts Pvt Ltd, India
17. Precision Auto Engineers, India
18. President Engineering Works, India
19. Sandeep Engineering Works, India
20. Syndicate Engineering Industries, India

ix) Welding Electrodes

1. For Mainline – Lincon make
 2. For Terminal – For root pass - Lincon Make
- For other passes – Lincon, D&H or equivalent make

x) Fire Fighting

Equipments

a) Fire

Extinguishers

1. Avon Services (Production & Agencies) Pvt. Ltd., Bombay
2. Kooverji Devshi & Co., Bombay
3. Zenith Fire Services, Bombay
4. Safex Fire Services, Bombay
5. Reliable (Fire Protection) India Ltd., Bombay
6. Brij Basi Hi
7. tech Udyog
8. Bharat Engg Works, India
9. Gunnebo India Ltd
10. Nitin Fire Protection Industries Ltd, India
11. Supremex Equipments, India
12. Vimal Fire Controls Pvt Ltd., India

b) Fire Hydrants, Monitors, Deluge Valve, Nozzles

1. Zenith
2. Minimax

LIST OF APPROVED PARTIES FOR BOUGHT OUT ITEMS	Doc No.	Rev	
	GAIL-ENG-GN-DOC-VL-001	0	
	Page 8 of 22		

3. Newage
4. HD Fire
5. Vijay Fire
6. Asco Strumech Pvt Ltd, India
7. Brij Basi Hi
8. tech Udyog
9. Gunnebo India Ltd
10. Nitin Fire Protection Pvt Ltd
11. Shah Bhogilal Jethamal & Brothers
12. Venus Pumps & Engineering Works

c) RRL Hose

1. Jayshree
2. Newage

d) Hoses

1. Ashit Sales Corporation, Bombay
2. Royal India Corporation, Bombay
3. Gayatri Industrial Corporation
4. Simplex Rubber Products Ltd., Ahmedabad
5. Zaverchand Marketing Pvt. Ltd., Baroda
6. Presidency Rubber Mill, Calcutta
7. The Cosmopolite, Calcutta
8. Simplex Rubber Products, Thane

e) Hose Delivery

1. Chhatarya Rubber & Chemical Industries,
2. Nitin Fire Protection Industries Ltd, India

f) Fire Hose Accessories

1. Asco Strumech Pvt Ltd
2. Brij Basi Hi-tech Udyog
3. Gunnebo India Ltd
4. Shah Bhogilal Jethamal & Brothers
5. Vimal Fire Controls Pvt Ltd., India

g) Heat Shrinkable Sleeves

1. Covalence Raychem (Berry Plastics Corporation)

LIST OF APPROVED PARTIES FOR BOUGHT OUT ITEMS	Doc No.	Rev	
	GAIL-ENG-GN-DOC-VL-001	0	
Page 9 of 22			

2. Canussa – CPS
3. CYG Changtong New Material company.

h) Cold Applied Tapes

1. Denso GmbH
2. Polyken (Berry Plastics Corporation)

i) PUR Coating

1. Powercrete (Berry Plastics Corporation)

j) Casing End Closure

1. Raci, Italy
2. Raychem RPG Limited

k) Casing Insulators

1. Raci, Italy
2. Raychem RPG Limited

l) Rockshield

1. Raychem RPG Limited

m) Warning Tape /Mesh

1. Sparco Multiplast Pvt. Ltd., Ahmedabad
2. M/s Raychem RPG Limited
3. Singhal Industries Private Limited

n) High Build Epoxy Coating

1. Berry Plastics – Powercrete
2. Specialty Polymer Canada
3. Denso Protal, Canada

o) Casing Insulators

1. Raci, Italy
2. Raychem RPG Limited
3. Veekay Vikram

xi) NDT Agency

LIST OF APPROVED PARTIES FOR BOUGHT OUT ITEMS	Doc No.	Rev	
	GAIL-ENG-GN-DOC-VL-001	0	
	Page 10 of 22		

1. NDT Services, Ahmedabad
2. GEECY Industrial Services Pvt. Ltd., Mumbai
3. Corrosion Control Services, Mumbai
4. Perfect Metal Testing & Inspection Agency, Calcutta
5. Inter Ocean Shipping Co., New Delhi
6. RTD, Mumbai
7. Sievert, Mumbai
8. X-Tech, Vizag

xii) Long Radius Bends

1. M/s BHEL, Trichy, Tamilnadu
2. M/s Jindal SAW Limited, (Koshi Works), U.P.
3. M/s PSL Limited, Gandhidham, Gujarat
4. M/s Welspun, Gujarat
5. M/s Fabricon, Belgium
6. M/s Sawan
7. M/s Gujarat Infra
8. M/s P K Tubes
9. M/s DEE Development
10. Pipefit Engineers Pvt. Ltd.

LIST OF APPROVED PARTIES FOR BOUGHT OUT ITEMS	Doc No.	Rev	
	GAIL-ENG-GN-DOC-VL-001	0	
Page 11 of 22			

2. LIST OF MATERIALS OF APPROVED BRAND AND/ OR MANUFACTURE

B. (CIVIL & STRUCTURE)

Unless otherwise specifically mentioned in the Schedule of Items, Contractor has to use materials as listed below, of only these brand names/Company's names, which are mentioned in the approved list for civil, water supply and sanitary items thereon.

CIVIL

Sr. No.	Items/ Name of Products	Make/ Brands/ Manufactures
1.	Reinforcement Steel	TATA,SAIL,RINL,IISCO,RATHI
2.	Cement	Ambuja,ACC,JK,Grasim,Ultratech,Birla,L&T,Ceme nt
3.	Structural Steel	TATA,SAIL,RINL,IISCO,ESSAR, ISPAT
4.	Structural Steel Tubes ISI Marked	TATA, JINDAL , SURYA , SWASTIK
5.	(a) Zinalume colour coated steel sheet(COIL) (b) Profile of Sheet(as per tender specification)	(a)Tata Blue scope, Dongbu Steel ,Union Steel, JSW STEEL Ltd. Kirby Building system India ltd ,Interach Building Product limited, Tata blue scope steel ,Lloyd Insulation India ltd, Everest Industries. Ltd. Modern Prefab System Pvt Ltd,Aster Building Solution Pvt.Ltd, Octamec Engineering Ltd,Jindal Mectec
6.	Polycarbonate Sheet	Sabic Innovative Plastic , Everest
7.	Synthetic Enamel Paint (1st quality only)	ICI Paint (Dulux), Asian Paint (Apolite), Berger Paints (Luxol). Goodlass Nerolac Paints (Nerolac), Jenson & Nicholson Paints Ltd (Borolac), Shalimar,
8.	Sheeting Screw	Corroshield, Buildex,
9.	Chemical for Antitermite treatment	DE- NOCIL Bombay, Pest Control of India, Trishul
10.	Wall care Putty for Base preparation (1st quality only)	Birla Wall care putty, Berger, Jenson & Nicholson, JK White
11.	White Cement (1st quality only)	Birla, JK
12.	Cement based Paints (1st quality only)	Super Snowcem, Duracem, Super Acrorem.

LIST OF APPROVED PARTIES FOR BOUGHT OUT ITEMS	Doc No.	Rev	
	GAIL-ENG-GN-DOC-VL-001	0	
Page 12 of 22			

13.	Acrylic Washable Distemper (1st quality only)	Asian, Berger, ICI Dulux, Jenson & Nicholson, Nerolac, Shalimar, Garware & Goodlass
14.	Plastic Emulsion Paint (1st quality only)	Asian, Berger, ICI, Nerolac, Jenson & Nicholson, Shalimar, Garware & Goodlass
15.	Exterior Acrylic Emulsion (1st quality only)	ICI (Weathercoat), Excel (Nerolac), Apex (Asian), Berger, Jenson & Nicholson, Shalimar, Garware & Goodlass
16.	Polymer based Paint	STP, CICO
17.	Concrete Admixture	Pidilite, Fosroc, CICO, Sika.
18.	Water proofing for cementitious surface IS-2645	Acrocrete & Acrocote, CICO, Fosroc, STP
19.	Hardeners	Ironite, Ferrok, Hardonate
20.	Construction Chemicals	Choksey, CICO, Forsroc, Sika
21.	GI Sheet ISI Marked	Multicolor, TATA, Bluescope, JSW, Colour Plus, Interarch, Lloyds, Jindal,
22.	Sheet Glass /Structural Glazing	Hindustan Pilkington Glass Works, Saint Gobain, Modi
23.	Multiell / Multiwall Polycarbonate Panel	M/s Coxwell Domes Engineering , Delhi, M/s Lexan , M/s Gallina India Pvt. Ltd.
24.	Cateye	TATA, STP
25.	Float Valve	Leader, Bombay Metal & Alloy Co, Bombay superflow.
26.	Cast Iron Pipes and Fittings	Hindustan Engineering Products Company Calcutta, S..L.C., Standard approved manufacturers of any other brand of fittings
27.	Asbestos Cement Pipes and Fittings	Ganga Asbestos Limited, U.P.; Hyderabad Asbestos Cement Products Limited; J.K. Super Pipe Industries, Nanded; Konark Cement and Asbestos Limited, Orissa; Maharashtra Asbestos Limited, Bombay; Poddar Industrial Corporation, Patna;

STRUCTURE

Sl. No.	Items/Name of Products	Makes/Brands/Manufactures
1	Structural Steel	SAIL / TATA / RINL / IISCO / ESSAR / ISPAT
2	Structural Steel Tubes ISI Marked	TATA / JINDAL / SURYA / SWASTIK
3	Synthetic Enamel Paint Ist Quality only	ICI Paint (Deluxe), Asian Paint (Apcolite), Shalimar Paint (Superlac), Goodlass, Nerolac Paint (Nerolac), Berger Paints

LIST OF APPROVED PARTIES FOR BOUGHT OUT ITEMS	Doc No.	Rev	
	GAIL-ENG-GN-DOC-VL-001	0	
	Page 13 of 22		

Any materials not fully specified in these specification and which may be offered for use in the works shall be subject to approval of Engineer, without which it shall not be used anywhere in the construction works.

NOTE: - Item/Vendor, which are not listed above, shall be subject to prior approval from Client/Consultant.

LIST OF APPROVED PARTIES FOR BOUGHT OUT ITEMS	Doc No.	Rev	
	GAIL-ENG-GN-DOC-VL-001	0	
Page 14 of 22			

3. LIST OF MATERIALS OF APPROVED BRAND AND/ OR MANUFACTURE

C. (INSTRUMENTATION)

I. PRESSURE GAUGES

1. AN Instruments Pvt Ltd
2. Badotherm Process Instruments
3. Baumer Bourdon Haenni S.A.S
4. British Rototherm Co Ltd
5. Budenberg Gauge Co Ltd
6. Dresser Inc
7. Forbes Marshall (Hyd) Pvt Ltd
8. General Instrument Consortium
9. H. Guru Instruments (South India) Pvt Ltd
10. Manometer (India) Pvt Ltd
11. Nagano Keiki Seisakusho Ltd
12. Hirlekar Precision, India
13. Waaree Instruments Ltd
14. Walchandnagar Industries Ltd (Tiwac Divn)
15. Wika Alexander Wiegand & Co GmbH
16. Wika Instruments India Pvt Ltd
17. Ashcroft India Pvt Ltd.

II. TEMPERATURE GAUGES

1. AN Instruments Pvt Ltd.
2. Badotherm Process Instruments B.V.
3. Bourdon Haenni S.A.

LIST OF APPROVED PARTIES FOR BOUGHT OUT ITEMS	Doc No.	Rev	
	GAIL-ENG-GN-DOC-VL-001	0	
Page 15 of 22			

4. Dresser Inc.
5. General Instruments Consortium
6. H. Guru Instruments (South India) Pvt. Ltd
7. Nagano Keiki Seisakusho Ltd
6. Sbeletro Mechanicals
8. TRAC

**III. FIELD INSTRUMENTS
(P, DP, F, L, T)**

1. ABB Ltd
2. Honeywell
3. Fuji Electric Instruments Co Ltd
4. Yokogawa
5. Invensys India Pvt.Ltd

IV. PRESSURE REGULATOR AND SLAM SHUT VALVE

1. Pietro Fiorentini S.P.A. (Italy)
2. Emerson
3. RMG-Regel Messtechnik (Germany)
4. Mokveld Valves BV (Netherlands)
5. Schlumberger (USA)
6. Gorter Controls B V (Netherlands)
7. Instromet International NV
8. Nirmal Industrial Controls Pvt Ltd. (up to 6" size only)
9. ESME Valves Ltd
10. Kaye & Macdonald Inc.
11. Nuovo Pignone S.P.A (Italy) (GE Oil Co.)
12. Richards Industries (Formerly Treloar)
13. Samson AG Mess-und Regeltechnik
14. Tormene Gas Technology
15. Dresser Inc, USA (upto 8" size, 300# class only)

LIST OF APPROVED PARTIES FOR BOUGHT OUT ITEMS	Doc No.	Rev	
	GAIL-ENG-GN-DOC-VL-001	0	
Page 16 of 22			

V. PRESSURE SAFETY VALVES

1. Keystone Valves (India) Pvt. Ltd.
2. Larson & Toubro Ltd.
3. Lesser GmbH & Co KG
4. Mekaster Engg Ltd..
5. Tyco Sanmar Ltd. (New Delhi)
6. Anderson Greenwood Crosby
7. BHEL (Trichy)
8. Curtiss Wright Flow Control Corporation
9. Dresser Inc.
10. Fukui Seisakusho Co. Ltd
11. Nakakita Seisakusho Co Ltd
12. Nuovo Pignone S.P.A (Italy) (GE Oil co)
13. Parcol S.P.A
14. Safety Systems UK Ltd
15. Tai Milano S.P.A
16. Weir Valves & Controls France
17. Bliss Anand Pvt Ltd.

VI. FLOW CONTROL VALVES

1. Fouress Engg. (New Delhi)
2. Fisher Xomox (New Delhi)
3. MIL Control Ltd. (Noida)
4. KOSO India Pvt Ltd
5. Samson Control (Thane)
6. Dresser Valves India Pvt Ltd.
7. Fisher Controls
8. Valvitalia Italy

LIST OF APPROVED PARTIES FOR BOUGHT OUT ITEMS	Doc No.	Rev	
	GAIL-ENG-GN-DOC-VL-001	0	
	Page 17 of 22		

9. CCI Valve technology
10. Flowserve Pvt Ltd.
11. Metso Singapore Pvt Ltd.
12. Instrumentation Ltd Palghat
13. Dresser Inc. USA

VII. INDICATORS & CONTROLLERS

1. Yokogawa
2. Eurotherm Chessel
3. Honeywell
4. Emerson

VIII. SS FITTINGS, INSTRUMENT VALVES & MANIFOLDS

1. Aura Inc.
2. Hoke
3. Excelsior Engg Works, India
4. Parker
5. Swagelok Co.
6. Swastic Engineering Works, India
7. Comfit & Valves Pvt.Ltd
8. Arya Crafts & Engg.Pvt. Ltd

IX. SS TUBES

1. Sandvik
2. Hoke
3. Parker
4. Swagelok Co.
5. Heavy metal & tubes LTD
6. Nuclear Fuel Complex .India
7. Ratnamani Metal & Tube Ltd
8. Jindal Saw

LIST OF APPROVED PARTIES FOR BOUGHT OUT ITEMS	Doc No.	Rev	
	GAIL-ENG-GN-DOC-VL-001	0	
	Page 18 of 22		

11. Honeywell Analytics
12. Net Safety Monitoring Inc.
13. Simtronics SAS

LIST OF APPROVED PARTIES FOR BOUGHT OUT ITEMS	Doc No.	Rev	
	GAIL-ENG-GN-DOC-VL-001	0	
Page 19 of 22			

4. **LIST OF RECOMMENDED MANUFACTURERS**

E. **(SHOP & FIELD PAINTING)**

I. **Indian Vendors**

1. Asian Paints(I) Ltd.
2. Berger Paints Ltd.
3. Goodlass Nerlolac Paints Ltd.
4. Jenson And Nicholson Paint Ltd & chokuGu Jenson & Nicholson Ltd.
5. Shalimar Paints Ltd.
6. Sigma Coating, Mumabai
7. CDC Carboline Ltd.
8. Premier Products Ltd.
9. Coromandel Paints & Chemicals Ltd.
10. Anupam Enterprises
11. Grand Polycoats
12. Bombay Paints Ltd.
13. Vanaprabha Esters & Glycer, Mumbai
14. Sunil Paints and Varnishes Pvt. Ltd.
15. Courtaulds Coating & Sealants India (Pvt.) Ltd.
16. Mark-chem Incorporated, Mumbai (for phosphating chemicals only)
17. VCM Polyurethane Paint (for polyurethane Paint only)

II. **Foreign Vendors for Overseas Products**

1. Sigma Coating, Singapore
2. Ameron, USA
3. Kansai Paint, Japan
4. Hempel Paint, USA
5. Valspar Corporation, USA

LIST OF APPROVED PARTIES FOR BOUGHT OUT ITEMS	Doc No.	Rev	
	GAIL-ENG-GN-DOC-VL-001	0	
Page 20 of 22			

6. Courtaulds Coating, UK.

Notes:

1. Bidder can select equipment of two different makes, selected from this VENDOR LIST and mention the same in the checklist for technical evaluation attached with the tender. The offered bid must include filled datasheet indicating make, model, size, rating of offered instrument/ equipment duly supported by sizing calculation of offered equipment (wherever applicable).
2. Vendors who have already supplied above equipment in other terminals of GAIL (I) Ltd, shall also be considered qualified for this tender provided the supplied equipment are commissioned and running successfully and they have not been put on holiday in list of Client/LEPL/ Other PSU
3. Equipment / Instruments of any make which is offered by one bidder and acceptable to GAIL (I) Ltd shall be accepted for other bidder also. After placement of order, on request of the successful bidder list of other qualified makes for a particular item (for which successful bidder wants to change the vendor) shall be provided.
4. Bidder shall take prior approval of the make / model no of the offered item and it shall be from the list given above. However additional vendors will be considered in exceptional cases, provided they have supplied for similar application to reputed gas transmission/distribution companies, in quantities at least half the numbers being supplied for this tender, and working satisfactorily for minimum 6 months. Documentary evidence substantiating above shall be submitted for taking approval.
5. For procuring bought out items from vendors other than those listed above, the same may be acceptable subject to the following:
 -
 - a) The vendor/ supplier of bought out item(s) is a manufacturer/ supplier of said item(s) for intended services and the sizes being offered is in their regular manufacturing supply range.
 - b) Should have supplied at least one single random length (i.e. 5.5 meters to 6.5 meters) for item assorted pipes / tubes and for other items, which are to be supplied in quantity on number-basis (other than assorted pipes / tubes) minimum 01 (One) number of same or higher in terms of size and rating as required for intended services. The bidder should enclose

LIST OF APPROVED PARTIES FOR BOUGHT OUT ITEMS	Doc No.	Rev	
	GAIL-ENG-GN-DOC-VL-001	0	
Page 21 of 22			

documentary evidences i.e. PO copies, Inspection Certificate etc. for the above, along with their bids.

- 6 For any other item(s) for which the vendor list is not provided, bidders can supply those item(s) from vendors/ suppliers who have earlier supplied same item(s) for the intended services in earlier projects and the item(s) offered is in their regular manufacturing/ supply range. The bidder is not required to enclose documentary evidences (PO copies, Inspection Certificate etc.) along with their offer, however in case of successful bidder, these documents shall require to be submitted by them within 30 days from date of Placement of Order for approval to CLIENT / LEPL.

- 7 The details of vendors indicated in this list are based on the information available with LEPL, Contractor shall verify capabilities of each vendor for producing the required quantity with. PMC does not guarantee any responsibility on the performance of the vendor. It is the contractor's responsibility to verify the correct status of vendor and quality control of each parties and also to expedite the material in time.

LIST OF APPROVED PARTIES FOR BOUGHT OUT ITEMS	Doc No.	Rev	
	GAIL-ENG-GN-DOC-VL-001	0	
Page 22 of 22			